

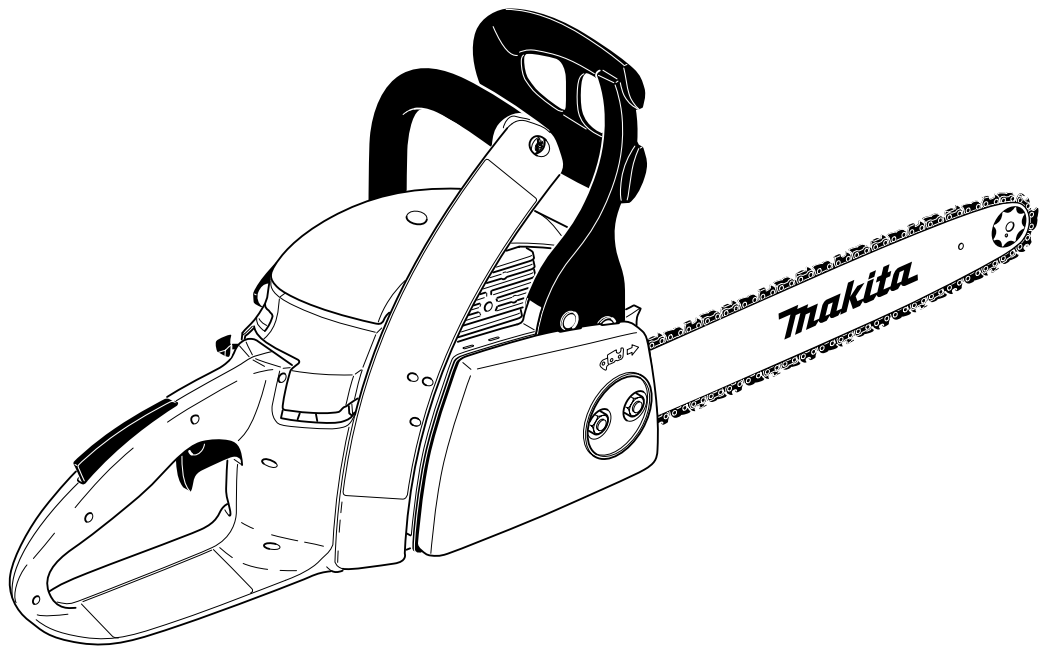

Instruction Manual



**DCS34
DCS4610**



Important:

Read this instruction manual carefully before putting the chain saw into operation and strictly observe the safety regulations!

Keep this Instruction Manual!

Thank you for purchasing a MAKITA product!

Congratulations on choosing a MAKITA chain saw! We are confident that you will be satisfied with this modern piece of equipment.

The DCS34, DCS4610 are very handy and robust chain saws with a new Design.

The automatic chain lubrication and maintenance-free electronic ignition ensure trouble-free operation, while the hand-saving anti-vibration system and ergonomic grips and controls make work easier, safer, and less tiring for the user.

The PS-34, chain saws are equipped with the latest safety features and meet all international standards. These features include: Hand guards on both handles, grip throttle lever lock, chain catch, safety saw chain, and chain brake. The chain brake can be actuated manually, and is also inertia-actuated automatically in case of kickback.

The following industrial property rights apply: DE 19722629.

In order to ensure the proper functioning and performance of your new chain saw, and to safeguard your own personal safety, it is imperative that you read this instruction manual thoroughly before operation. Be especially careful to observe all safety precautions! Failure to do so can result in serious injury to the operator and/or bystanders!



| Table of contents | Page |
|--|-------|
| Packing | 2 |
| Delivery inventory | 3 |
| Symbols | 3 |
| SAFETY PRECAUTIONS | |
| General precautions | 4 |
| Protective equipment | 4 |
| Fuels / Refuelling | 5 |
| Putting into operation | 5 |
| Kickback | 6 |
| Working behavior/Method of working | 6-7 |
| Transport and storage | 8 |
| Maintenance | 8 |
| First aid | 8 |
| Technical data | 9 |
| Denomination of components | 9 |
| PUTTING INTO OPERATION | |
| Mounting the guide bar and saw chain | 10-11 |
| Tightening the saw chain | 11 |
| Chain brake | 12 |
| Fuels | 13-14 |
| Refuelling | 14 |
| Adjusting the chain lubrication | 15 |
| Starting the engine | 16 |
| Cold start | 16 |
| Warm start | 16 |
| Stopping the engine..... | 16 |
| Checking the chain brake | 17 |
| Set idle speed | 17 |
| MAINTENANCE | |
| Sharpening the saw chain | 18-19 |
| Cleaning the brake band and sprocket interior | 20 |
| Cleaning the guide bar, lubricating the sprocket nose .. | 20 |
| Replacing the saw chain | 21 |
| Replacing the suction head | 21 |
| Cleaning the air filter | 21 |
| Replacing the spark plug | 22 |
| Checking the ignition spark | 22 |
| Instructions for periodic maintenance | 23 |
| Service, spare parts and guarantee | 23-24 |
| Troubleshooting | 24 |
| Extract from spare parts list | 25 |
| Accessories | 25 |
| Conformity Declaration | 27 |

Packing

The MAKITA chain saw will be delivered in a protective cardboard box to prevent transport damage.

Cardboard is a basic raw material and is consequently reuseable or suitable for recycling (waste paper recycling).



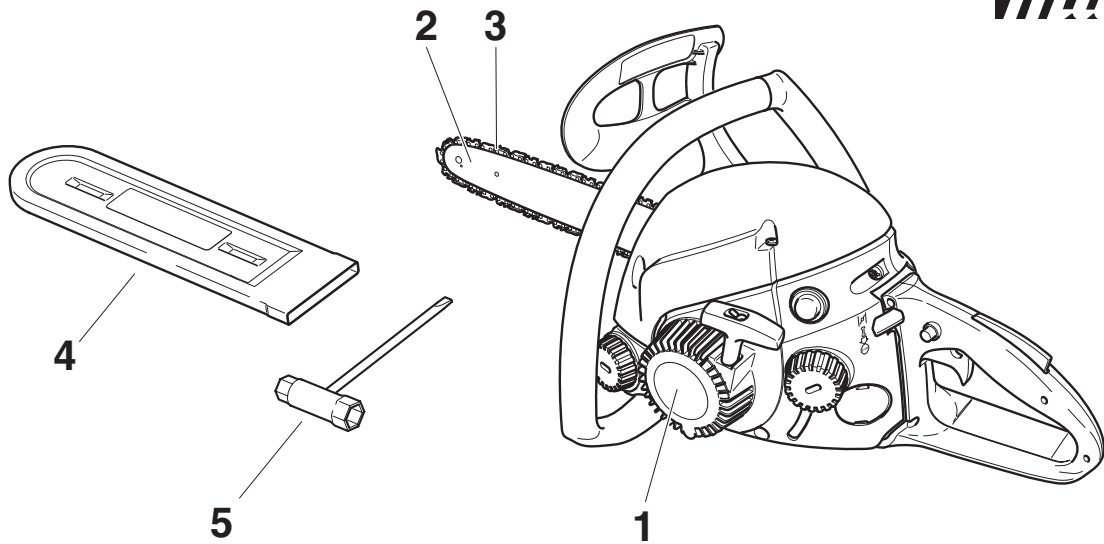

- 1. Chain saw
- 2. Guide bar
- 3. Saw chain
- 4. Chain protection cover
- 5. Assembly tool
- 6. Instruction manual (not shown)

In case one of the parts listed should not be included in the delivery inventory, please consult your sales agent.

Symbols

You will note the following symbols on the chain saw and when studying this instruction manual:

| | | | |
|--|---|--|--------------------------------|
| | Read the instruction manual and follow all warnings and safety instructions! | | Stop engine! |
| | Particular care and caution! | | Start the engine |
| | Forbidden! | | Caution, kickback! |
| | Wear protective helmet, eye and ear protection! | | Chain brake |
| | Wear protective gloves! | | Fuel and oil mixture |
| | No smoking! | | Chain oil fill/oil pump |
| | No open fire! | | First aid |
| | Combination Start/Stop (I/O) switch, choke | | Recycling |
| | Direction of chain travel | | Sign CE |

SAFETY PRECAUTIONS

Intended use

Power chain saws

This power chain saw may be used only for sawing wood out of doors. It is intended for the following uses depending on its class:

- **Professional and mid-class:** Use on small, medium and large trees: felling, limb removal, cutting to length, thinning.
- **Hobbyklasse:** Occasional use on small trees, fruit-tree care, felling, limb removal, cutting to length.

Unauthorised users:

Persons who are not familiar with the Instruction Manual, children, young people, and persons under the influence of drugs, alcohol or medication must not use this saw.

General precautions

- **To ensure correct operation the user has to read this instruction manual** to make himself familiar with the characteristics of the chain saw. Users insufficiently informed will endanger themselves as well as others due to improper handling.
- It is recommended to lend the chain saw only to people who are experienced in working with chain saws. Always hand over the instruction manual.
- First users should ask the dealer for basic instructions to become familiarized with the characteristics of engine powered sawing or even attend a recognized course of instruction.
- Children and young persons aged under 18 years must not be allowed to operate the chain saw. Persons over the age of 16 years may, however, use the chain saw for the purpose of being trained as long as they are under the supervision of a qualified trainer.
- Use chain saws always with the utmost care and attention.
- Operate the chain saw only if you are in good physical condition. If you are tired, your attention will be reduced. Be especially careful at the end of a working day. Perform all work calmly and carefully. The user has to accept liability for others.
- Never use the chain saw after having consumed alcohol, drugs or medication.
- A fire extinguisher must be available in the immediate vicinity when working in easily inflammable vegetation or when it has not rained for a long time (danger of fire).

Protective equipment

- **In order to avoid head, eye, hand or foot injuries as well as to protect your hearing the following protective equipment must be used during operation of the chain saw:**
- The kind of clothing should be appropriate, i. e. it should be tight-fitting but not be a hindrance. Do not wear jewellery or clothing which could become entangled with bushes or shrubs. If you have long hair, always wear a hairnet!
- It is necessary to wear a protective helmet whenever working with the chain saw. The **protective helmet (1)** is to be checked in regular intervals for damage and is to be replaced after 5 years at the latest. Use only approved protective helmets.
- The **face shield (2)** of the protective helmet (or the goggles) protects against sawdust and wood chips. During operation of the chain saw always wear a goggle or a face shield to prevent eye injuries.
- Wear adequate **noise protection equipment** (ear muffs (3), ear plugs, etc.). Octave brand analysis upon request.
- The **safety jacket (4)** is provided with special signal-coloured shoulder straps and is comfortable and easy to care for.
- The **protective brace and bib overall (5)** is made of a nylon fabric with 22 layers and protects against cuts. We strongly recommend its use.

- **Protective gloves (6)** made of thick leather are part of the prescribed equipment and must always be worn during operation of the chain saw.

- During operation of the chain saw **safety shoes or safety boots (7)** fitted with anti skid sole, steel toe caps and protection for the leg must always to be worn. Safety shoes equipped with a protective layer provide protection against cuts and ensure a secure footing.

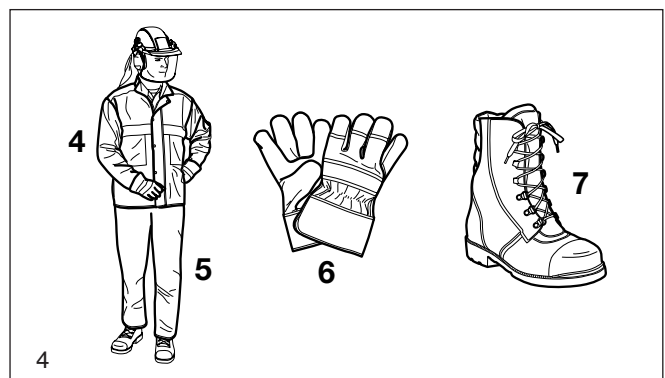
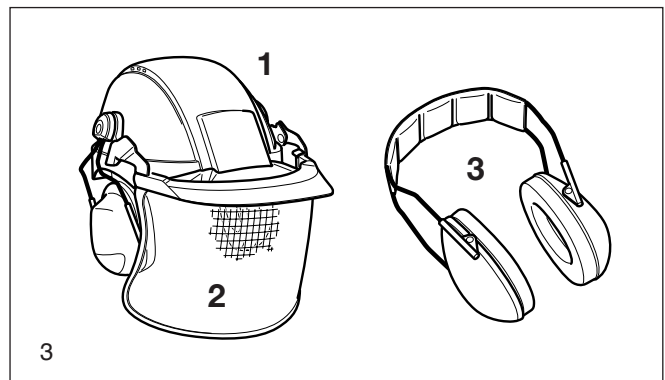
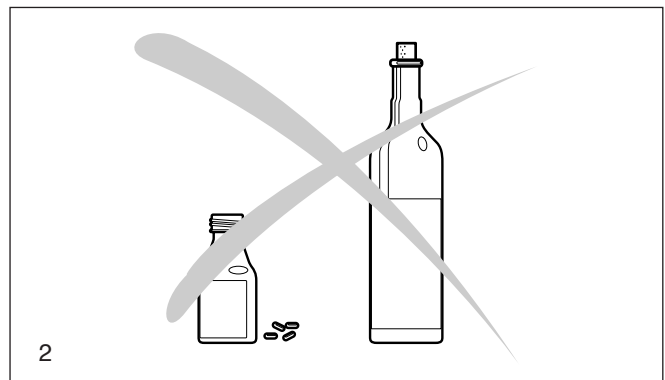
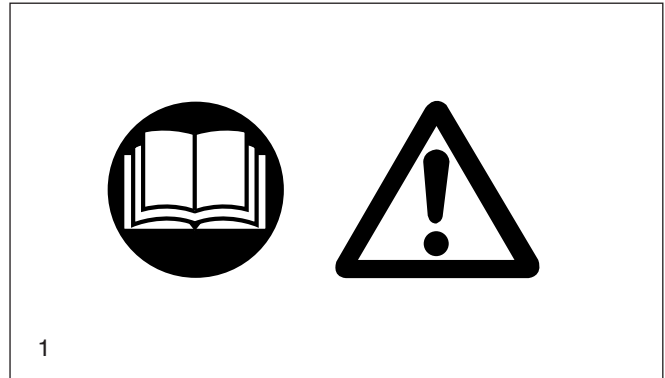

Fuels / Refuelling

- Stop the engine before refuelling the chain saw.
- Do not smoke or work near open fires (5).
- Let the engine cool down before refuelling.
- Fuels can contain substances similar to solvents. Eyes and skin should not come in contact with mineral oil products. Always wear protective gloves when refuelling. Frequently clean and change protective clothes. Do not breathe in fuel vapors. Inhalation of fuel vapours can be hazardous to your health.
- Do not spill fuel or chain oil. When you have spilt fuel or oil immediately clean the chain saw. Fuel should not come in contact with clothes. If your clothes have come in contact with fuel, change them at once.
- Ensure that no fuel or chain oil oozes into the soil (environmental protection). Use an appropriate base.
- Refuelling is not allowed in closed rooms. Fuel vapors will accumulate near the floor (explosion hazard).
- Ensure to firmly tighten the screw caps of the fuel and oil tanks.
- Change the place before starting the engine (at least 3 m from the place of refuelling) (6).
- Fuel cannot be stored for an unlimited period of time. Buy only as much as will be consumed in the near future.
- Use only approved and marked containers for the transport and storage of fuel and chain oil. Ensure children have no access to fuel or chain oil.

Putting into operation

- **Do not work on your own. There must be someone around in case of an emergency (within shouting distance).**
- Ensure that there are no children or other people within the working area. Pay attention to any animals in the working area, as well (7).
- **Before starting work the chain saw must be checked for perfect function and operating safety according to the prescriptions.**

Check especially the function of the chain brake, the correct mounting of the guide bar, the correct sharpening and tightening of the chain, the firm mounting of the sprocket guard, the easy motion of the throttle lever and the function of the throttle lever lock, the cleanliness and dryness of the handles, and the function of the ON/OFF switch.

- Start the chain saw only after complete assembly and inspection. Operation of the device is only permitted after all the appropriate accessories are attached!
- Before starting the chain saw ensure that you have a safe footing.
- Put the chain saw into operation only as described in this instruction manual (8). Other starting methods are not allowed.
- When starting the chain saw it must be well supported and securely held. The guide bar and chain must not be in contact with any object.
- **When working with the chain saw always hold it with both hands.** Take the back handle with the right hand and the tubular handle with the left hand. Hold the handles tightly with your thumbs facing your fingers.
- **CAUTION: When releasing the throttle lever the chain will keep on running for a short period of time (free-wheeling).**
- Continuously ensure that you have a safe footing.
- Hold the chain saw such that you will not breathe in the exhaust gas. Do not work in closed rooms (danger of poisoning).
- **Switch off the chain saw immediately if you observe any changes in its operating behavior.**
- **The engine must be switched off before checking the chain tension, tightening the chain, replacing it or clearing malfunctions (9).**
- When the sawing device is hit by stones, nails or other hard objects, switch off the engine immediately and check the sawing device.
- When stopping work or leaving the working place switch off the chain saw (9) and put it down such that nobody is endangered.
- Do not put the overheated power chain saw in dry grass or on any inflammable objects. The muffler is very hot (danger of fire).
- **CAUTION: Oil dropping from the chain or guide bar after having stopped the saw chain will pollute the soil. Always use an appropriate base.**



5

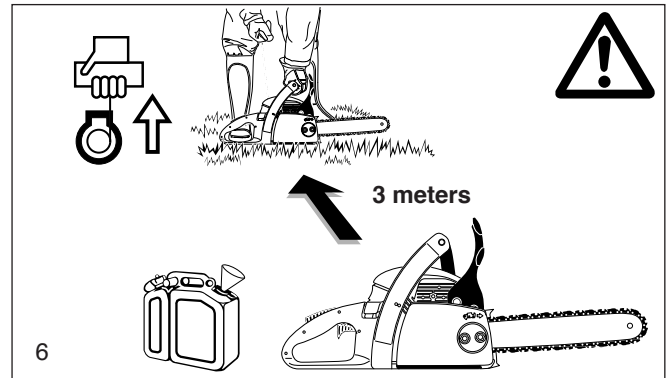

6

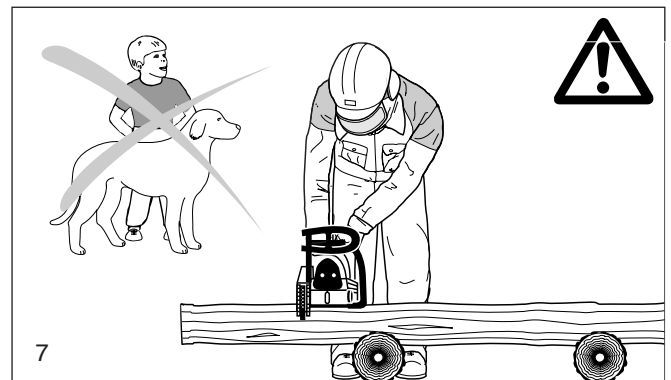

7

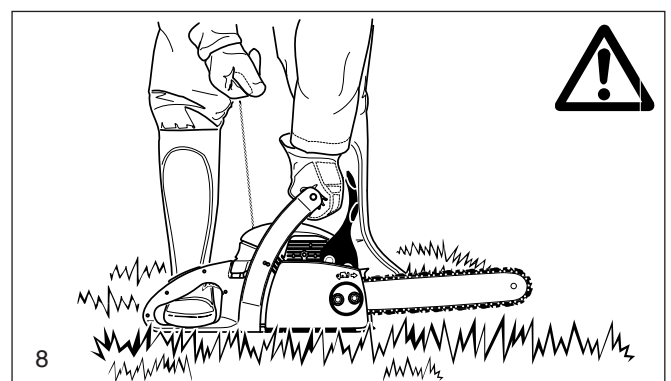

8

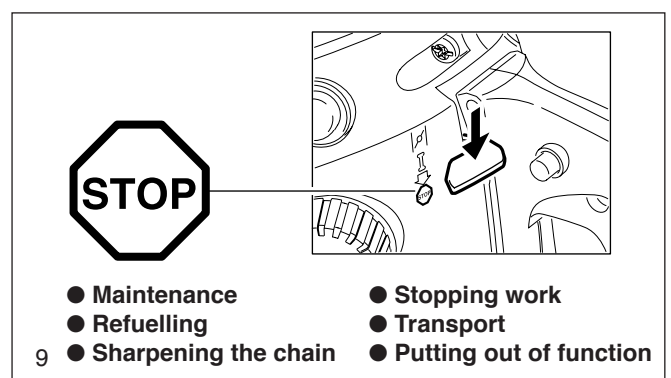

9

Kickback

- When working with the chain saw dangerous kickbacks may occur.
- Kickback occurs when the upper part of the end of the guide bar inadvertently touches wood or other hard objects (10).
- This causes the saw to be thrown back toward the user with great force and out of control. **Risk of injury!**

In order to prevent kickback, follow these rules:

- Only specially-trained persons should perform plunge cuts, i.e., piercing timber or wood with the tip of the saw!
- Always observe the end of the guide bar. Be careful when continuing an already started cut.
- When starting to cut the chain must be running.
- Ensure that the chain is always sharpened correctly. Pay special attention to the height of the depth limiter.
- Never cut several branches at the same time. When cutting a branch ensure that no other branch is touched.
- When crosscutting a trunk be aware of the trunks next to it.

Working behavior/Method of working

- Only use the chain saw during good light and visibility periods. Be aware of slippery or wet areas, and of ice and snow (risk of slipping). The risk of slipping is extremely high when working on recently peeled wood (bark).
- Never work on unstable surfaces. Make sure that there are no obstacles in the working area, risk of stumbling. Always ensure that you have a safe footing.
- Never saw above your shoulder height (11).
- Never saw while standing on a ladder (11).
- Never climb up into trees to perform sawing with the chain saw.
- Do not work leaning too far over.
- Guide the chain saw in such a way that no part of your body is within the elongated swivelling range of the saw (12).
- Use the chain saw for sawing wood only.
- Avoid touching the ground with the chain saw while it is still running.
- Never use the chain saw for lifting up or removing pieces of wood or other objects.
- Remove foreign objects such as sand, stones and nails found within the working area. Foreign objects may damage the sawing device and can cause dangerous kickback.
- When sawing pre-cut timber use a safe support (sawing jack, 13). Do not steady the workpiece with your foot, and do not allow anyone else to hold or steady it.
- Secure round pieces against rotation.
- **For cutting down trees or performing crosscuts the spike bar (13, Z) must be applied to the wood to be cut.**
- Before performing a **crosscut** firmly apply the spike bar to the timber, only then can the timber be cut with the chain running. For this the chain saw is lifted at the back handle and guided with the tubular handle. The spike bar serves as a centre of rotation. Continue by slightly pressing down the tubular handle and simultaneously pulling back the chain saw. Apply the spike bar a little bit deeper and once again lift the back handle.
- **When the timber must be pierced for cutting or longitudinal cuts are to be performed it is urgently recommended to have this carried out by specially trained persons only** (high risk of kickback).
- Do **longitudinal - lengthwise - cuts** at the lowest possible angle (14). Be very careful when doing this type of cut, as the spike bar cannot grip.
- The saw must be running whenever you remove the chain saw from the wood.
- When performing several cuts the throttle lever must be released in between.

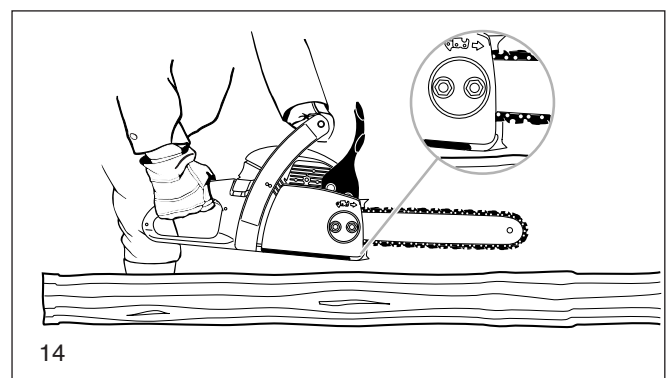
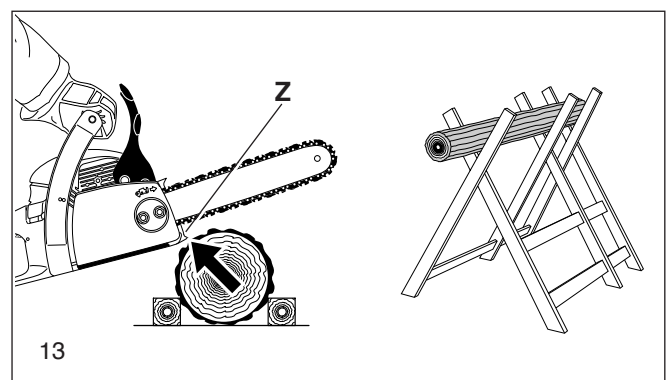
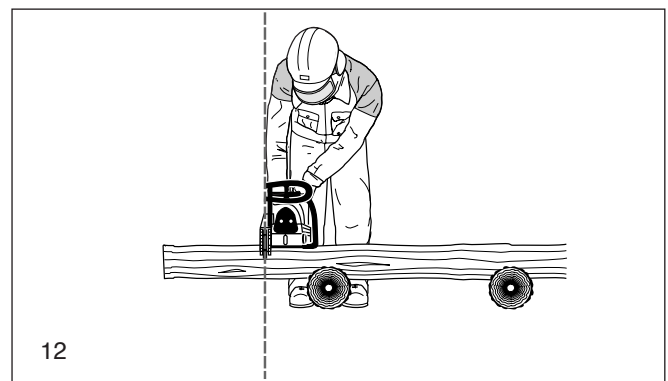
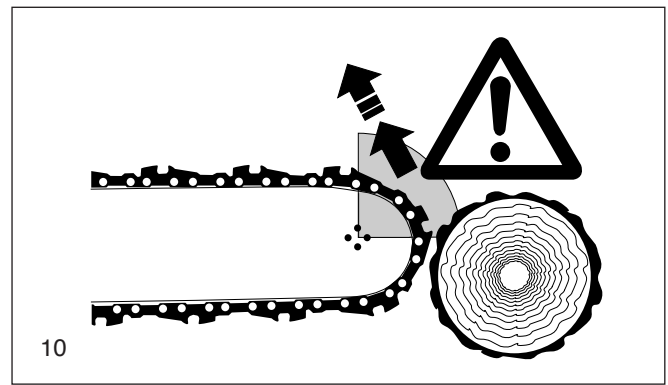

- Be careful when cutting splintery wood. Cut pieces of wood may be pulled along (risk of injuries).
- When cutting with the upper edge of the guide bar, the chain saw may be pushed in the direction of the user if the chain gets clamped. For this reason use the lower edge of the bar whenever possible. The chain saw will then be pushed away from you (15).
- If the timber is under tension (16), first cut the pressure side (A). Then the crosscut can be performed on the tension side (B). Thus clamping of the guide bar can be avoided.

CAUTION: People felling trees or cutting of branches must be specially trained. High risk of injuries!

- When cutting of branches, the chain saw should be supported on the trunk. Do not use the end of the bar for cutting (risk of kickback).
- Be aware of branches under tension. Do not cut free branches from below.
- Never perform detensioning cuts while standing on the trunk.
- **Before cutting down a tree ensure that**
 - a) only those people are within the working area which are actually involved in cutting down the tree.
 - b) every worker involved can withdraw without stumbling (the people should withdraw backwards in a diagonal line, i. e. at a degree of 45°).
 - c) the bottom part of the trunk is free from foreign objects, underbrush and branches. Make sure to have a safe footing (risk of stumbling).
 - d) the next working place is at least 2 1/2 tree lengths away (17). Before cutting down the tree check the direction of fall and make sure that there are neither people nor objects within a distance of 2 1/2 tree lengths.

Judging the tree:

Direction of hanging - loose or dry branches - height of the tree - natural overhang - is the tree rotten?

- Take into account the direction and speed of the wind. If strong gusts are occurring, do not do any felling.

Cutting the roots:

Start with the strongest root. First do the vertical and then the horizontal cut.

- **Notching the trunk (18, A):**
The notch determines the direction of fall and guides the tree. The trunk is notched perpendicular to the direction of fall and penetrates 1/3 - 1/5 of the trunk diameter. Perform the cut near the ground.
- When correcting the cut, always do so over the whole width of the notch.
- **Cut down** the tree (19, B) above the bottom edge of the notch (D). The cut must be exactly horizontal. The distance between both cuts must be approx. 1/10 of the trunk diameter.
- The **material between both cuts (C)** serves as a hinge. Never cut it through, otherwise the tree will fall without any control. Insert felling wedges in time.
- Secure the cut only with wedges made of plastic or aluminium. Do not use iron wedges. If the saw hits an iron wedge the chain can be seriously damaged or torn.
- When cutting down a tree always stay sideways of the falling tree.
- When withdrawing after having performed the cut, be alert for falling branches.
- When working on sloping ground the user of the chain saw must stay above or sideways of the trunk to be cut or the tree already cut down.
- Be alert for trunks which may roll towards you.

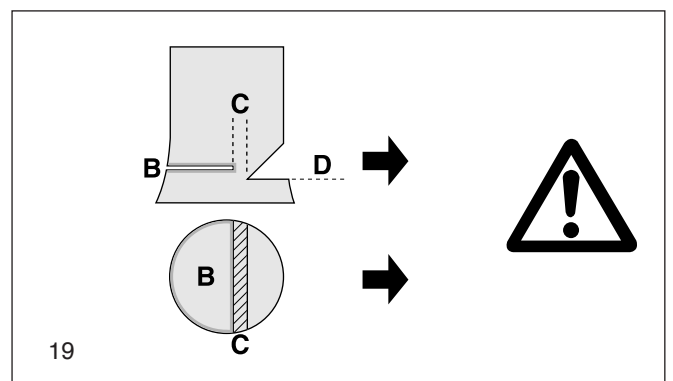
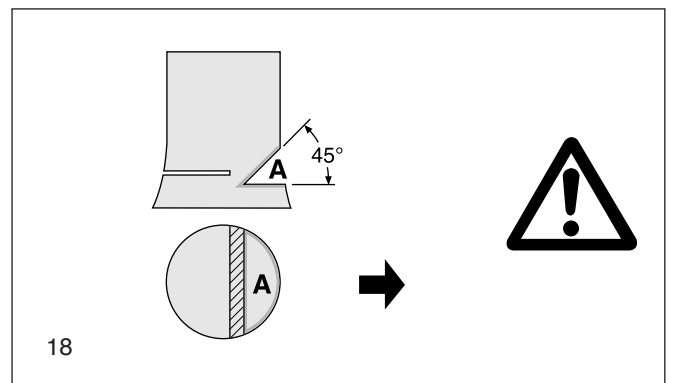
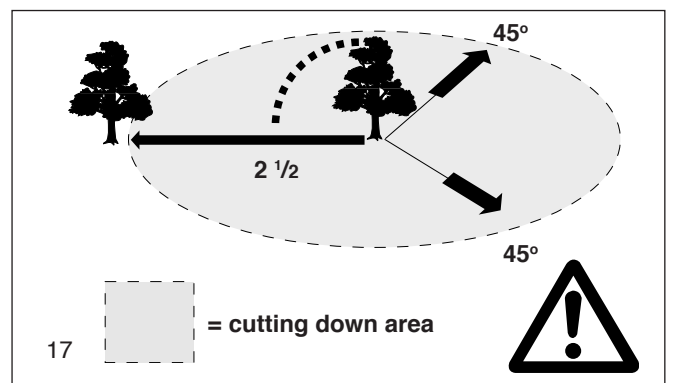
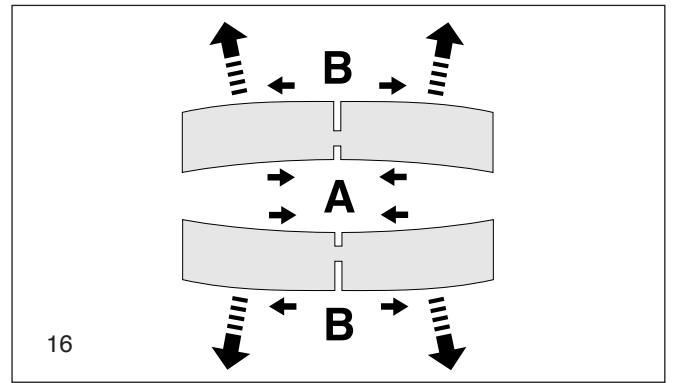
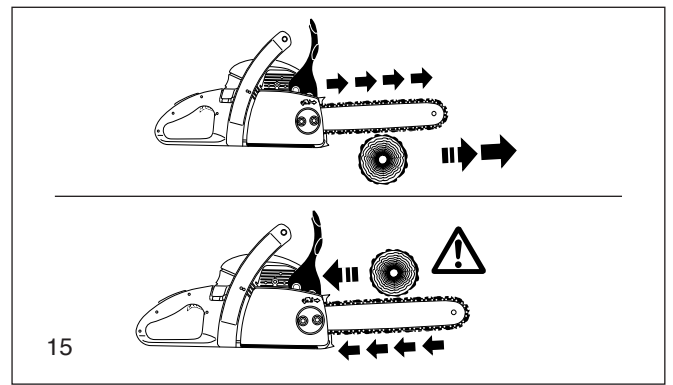

Transport and storage

- **When changing your location during work switch off the chain saw and actuate the chain brake in order to prevent an inadvertent start of the chain.**
- **Never carry or transport the chain saw with the chain running.**
- When transporting the chain saw over long distances the guide bar protection cover (delivered with the chain saw) must be applied.
- Carry the chain saw with the tubular handle. The guide bar points backwards (20). Avoid coming in contact with the muffler (danger of burns).
- Ensure safe positioning of the chain saw during car transportation to avoid fuel or chain oil leakage.
- Store the chain saw safely in a dry place. It must not be stored outdoors. Keep the chain saw out of reach of children.
- Before storing the chain saw over a long period of time or shipping it the fuel and oil tanks must be completely emptied.

Maintenance

- **Before performing maintenance work switch off the chain saw (21) and pull out the plug cap.**
- Before starting work always check the operating safety of the chain saw, in particular the function of the chain brake. Make sure that the chain is always sharpened and tightened correctly (22).
- Operate the chain saw only at a low noise and emission level. For this ensure the carburetor is adjusted correctly.
- Regularly clean the chain saw.
- Regularly check the tank cap for tightness.

Observe the accident prevention instructions issued by trade associations and insurance companies. Do not perform any modifications on the chain saw. You will put your safety at risk.

Perform only the maintenance and repair works described in the instruction manual. All other work must be carried out by MAKITA Service.

Use only original MAKITA spare parts and accessories.

Using spare parts other than original MAKITA parts or accessories and guide bar/chain combinations or lengths which are not approved bring a high risk of accidents. We cannot accept any responsibility for accidents and damage resulting from using sawing devices or accessories which have not been approved.

First aid

For the event of a possible accident, please make sure that a first aid kit is always immediately available close by. Immediately replace any items used from the first aid box.

When calling for help, give the following information:

- Place of the accident
- What happened
- Number of injured people
- Kind of injuries
- Your name!

NOTE

Individuals with poor circulation who are exposed to excessive vibration may experience injury to blood vessels or the nervous system.

Vibration may cause the following symptoms to occur in the fingers, hands or wrists: "Falling asleep" (numbness), tingling, pain, stabbing sensation, alteration of skin colour or of the skin. **If any of these symptoms occur, see a physician!**

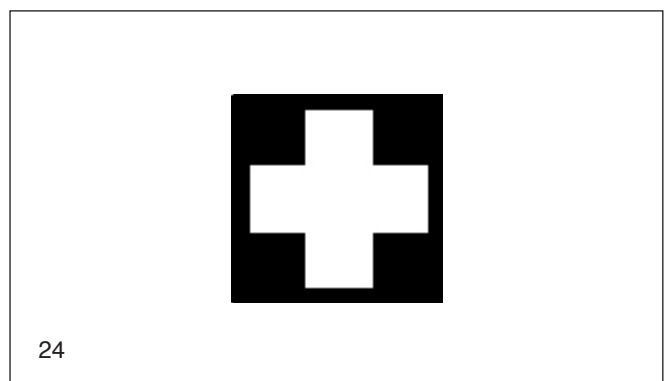
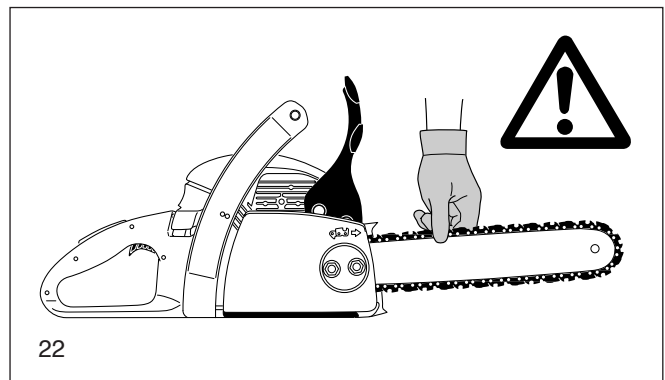
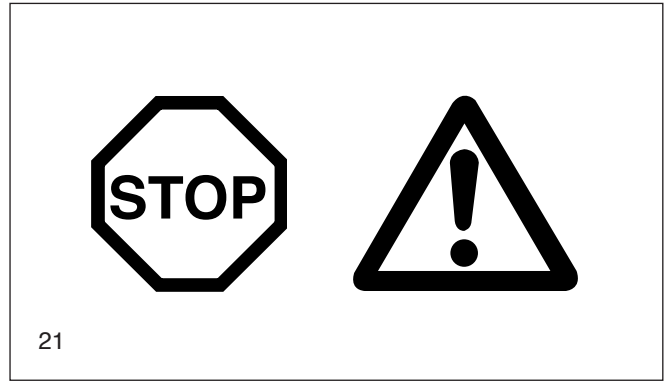
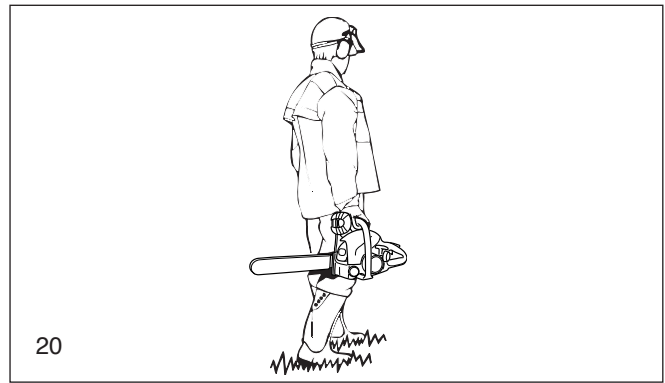

Technical data

| | | DCS34 | DCS4610 |
|--|------------------|--|----------------|
| Stroke volume | cm ³ | 33 | 45,1 |
| Bore | mm | 37 | 43 |
| Stroke | mm | 31 | |
| Max. power at speed | kW / 1/min | 1,3 / 9.000 | 1,7 / 9.000 |
| Max. torque at speed | Nm / 1/min | 1,7 / 6.500 | 2,4 / 6.500 |
| Idling speed / Max. engine speed with guide bar and chain | 1/min | 2.800 / 12.200 | 2.600 / 12.600 |
| Coupling speed | 1/min | 3.900 | |
| Sound pressure level $L_{pA,av}$ at the workplace per ISO 7182 ¹⁾ | dB (A) | 98,5 | 99,9 |
| Sound power level $L_{WA,av}$ per ISO 9207 ¹⁾ | dB (A) | 105 | 109,6 |
| Vibration acceleration $a_{h,av}$ per ISO 7505 ¹⁾ | | | |
| - Tubular handle | m/s ² | 5 | 6,1 |
| - Rear handle | m/s ² | 7 | 9,1 |
| Carburetor (diaphragm carburetor) | Type | ZAMA | |
| Ignition system | Type | PHELON | |
| Spark plug | Type | NGK BPRM 7A | |
| Electrode gap | mm | 0,5 | |
| or spark plug | Type | | |
| Fuel consumption at max. load per ISO 7293 | kg/h | 0,71 | 0,94 |
| Specific consumption at max. load per ISO 7293 | g/kWh | 550 | 580 |
| Fuel tank capacity | l | 0,37 | |
| Chain oil tank capacity | l | 0,25 | |
| Mixture ratio (fuel/two-stroke oil) | | | |
| - when using MAKITA oil | | 50 : 1 | |
| - when using Aspen Alkalyt (two-stroke fuel) | | 50 : 1 (2%) | |
| - when using other oils | | 40 : 1 (quality grade: JASO FC or ISO EGD) | |
| Chain brake | | engages manually or in case of kickback | |
| Chain speed ²⁾ | m/s | 17,1 | |
| Sprocket pitch | inch | 3/8 | |
| Number of teeth | Z | 6 | |
| Chain type - see the Extract from the spare-parts list | | 092 | |
| Pitch / Driving element strength | inch | 3/8 / .050 | |
| Guide bar, length of a cut | cm | 35, 40 | |
| Guide-bar type - see the Extract from the spare-parts list | | | |
| Weight (fuel tank empty, without chain and guide bar) | kg | 4,7 | 4,75 |

¹⁾ Figures derived in equal part from idle, full-load, and top-speed operation.

²⁾ At max. power

Denomination of components

Identification plate (20)

Indicate when ordering spare parts



Serial number
Year of manufacture

- 1 Handle
- 2 Filter cover
- 3 Muffler
- 4 Spike bar (Toothed stop)
- 5 Retaining nut
- 6 Chain catch
- 7 Sprocket guard
- 8 Adjusting screws for carburetor
- 9 Hand guard (release for chain brake)
- 10 Starter grip
- 11 Fuel pump (Primer)
- 12 Combination Start/Stop (I/O) switch, choke
- 13 Stop knob for halfway throttle
- 14 Throttle lever
- 15 Safety locking button
- 16 Rear hand guard
- 17 Fuel tank cap
- 18 Fuel tank fill-level window
- 19 Fan housing with starting assembly
- 20 Identification plate
- 21 Oil tank cap
- 22 Oil tank fill-level window
- 23 Tubular handle
- 24 Guide bar
- 25 Chain

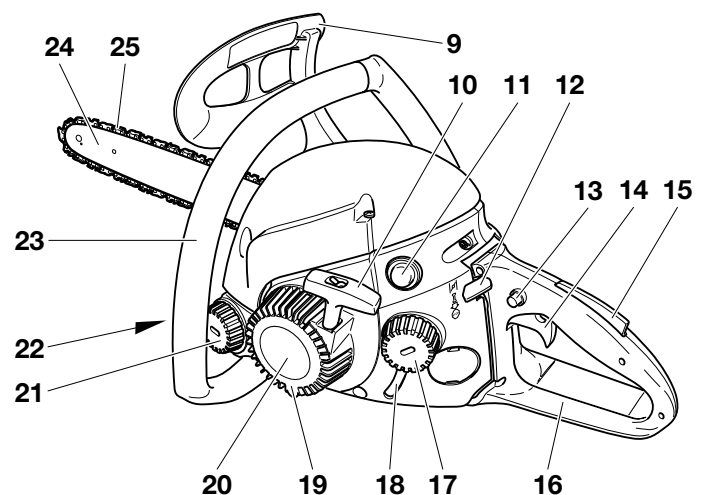
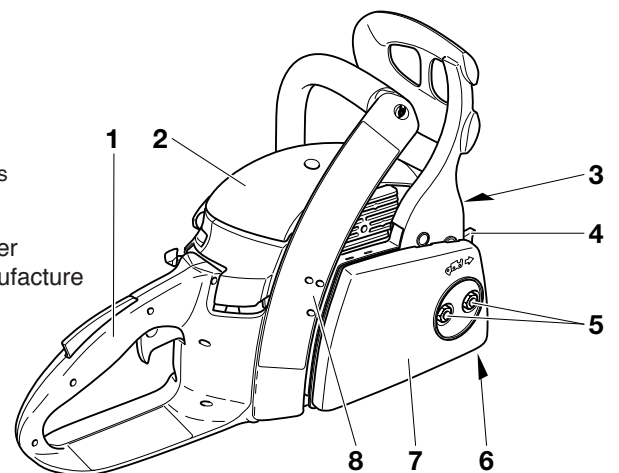

PUTTING INTO OPERATION

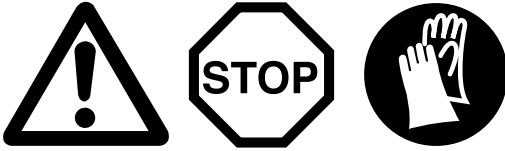

CAUTION:

Before doing any work on the guide bar or chain, always switch off the engine and pull the plug cap off the spark plug (see „Replacing the spark plug“). Always wear protective gloves!

CAUTION:

Start the chain saw only after having assembled it completely and inspected!

A

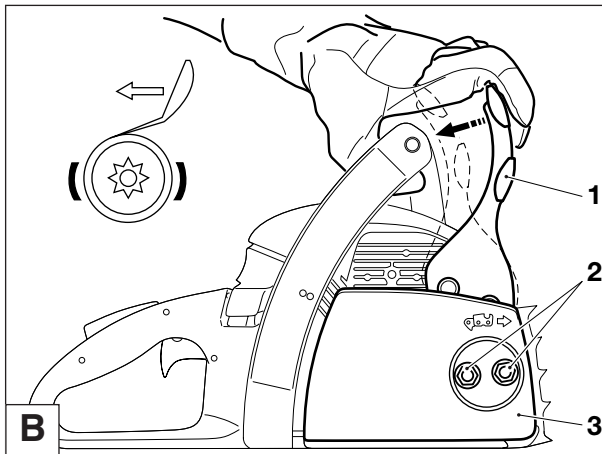

Mounting the guide bar and saw chain

Use the universal wrench delivered with the chain saw for the following work.

Put the chain saw on a stable surface and carry out the following steps for mounting the guide bar and chain:

Release the chain brake by pulling the hand guard (1) in direction of arrow.

Unscrew retaining nuts (2).

Pull off the sprocket guard (3).

B

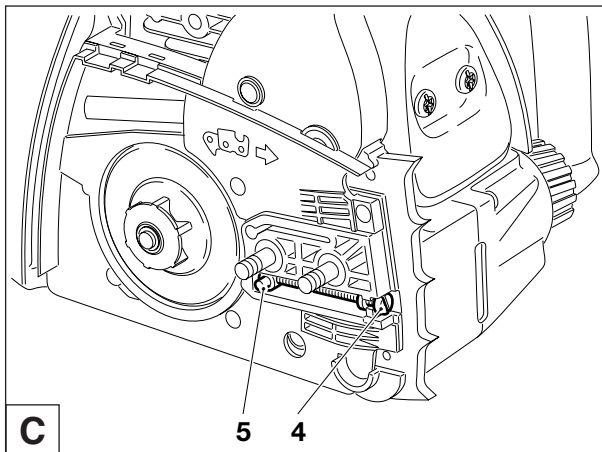

Turn the chain adjusting screw (4) to the left (counterclockwise) until the pin (5) is at the left stop.

C

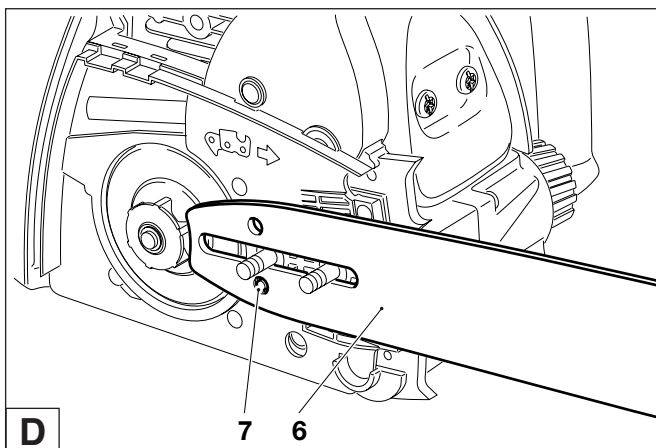

Position the guide bar (6). Make sure that the pin (7) of the chain tightener is in the hole on the guide bar.

D

Lift the chain (8) over the sprocket (9). Using your right hand, guide the chain into the top guide groove on the guide bar (10). Note that the cutting edges along the top of the chain must point in the direction of the arrow (11)!

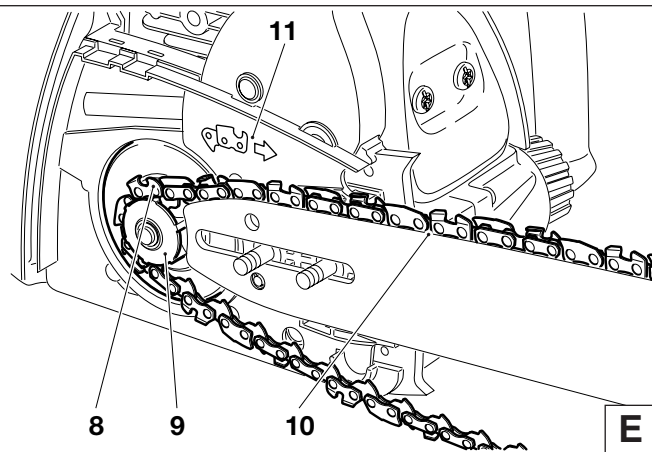

Pull the chain (8) around the sprocket nose (12) of the guide bar in the direction of the arrow.

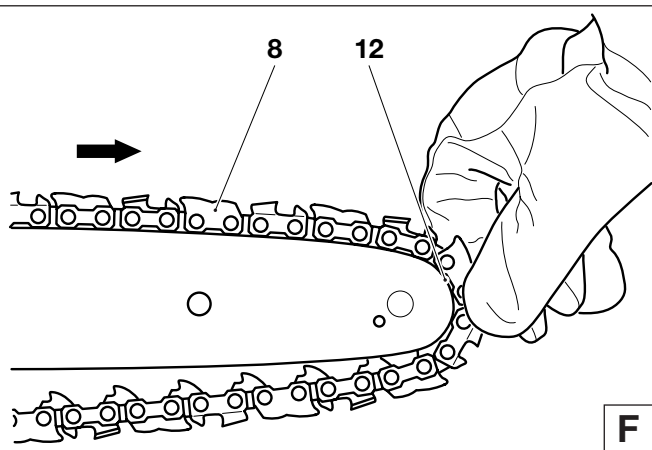

Replace the sprocket guard (3), putting the chain (8) over the chain catcher (13). Manually tighten the retaining nuts (2).

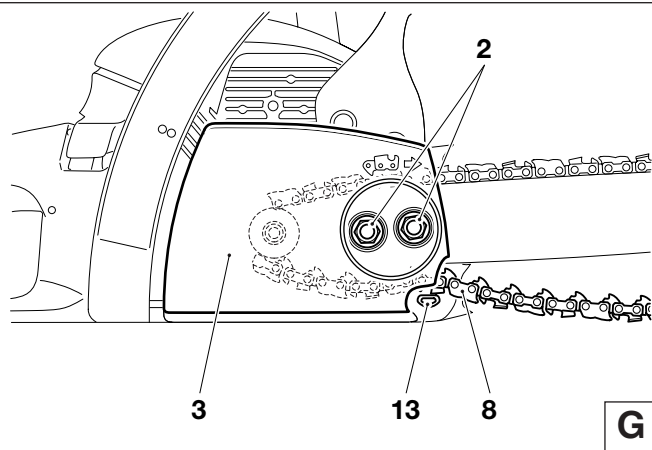

Tightening the saw chain

Turn the chain tightener (C/4) to the right (clockwise) until the chain engages the guide groove of the bottom side of the bar (see circle).

Slightly lift the end of the guide bar and turn the chain adjusting screw (C/4) to the right (clockwise) until the chain rests against the bottom side of the guide bar.

While still holding up the guide bar, tighten the retaining nut s(2) with the universal wrench.

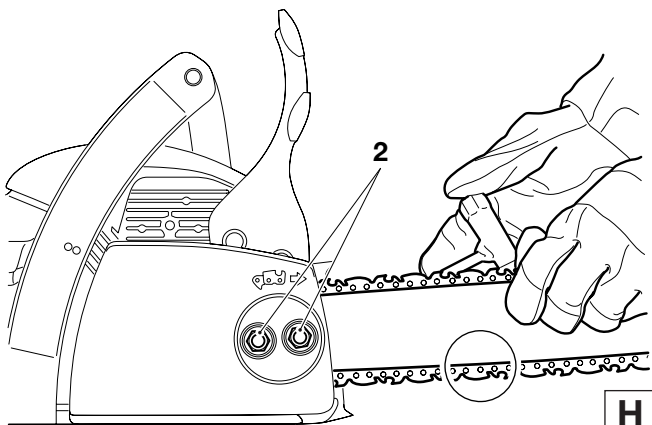

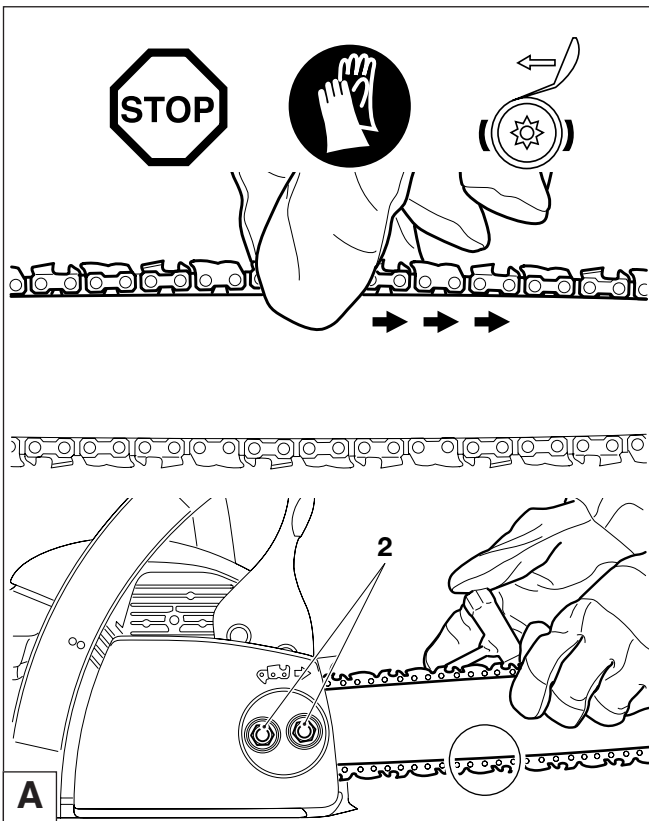

Checking the chain tension

The tension of the chain is correct if the chain rests against the bottom side of the guide bar and can still be easily turned by hand.

While doing so the chain brake must be released.

Check the chain tension frequently - new chains tend to get longer during use!

When checking the chain tension the engine must be switched off.

NOTE:

It is recommended to use 2-3 chains alternatively.

In order to guarantee uniform wear of the guide bar the bar should be turned over whenever replacing the chain.

Tightening the saw chain

Turn the retaining nuts (2) approximately one turn with the universal wrench. Slightly lift the end of the guide bar and turn the chain adjusting screw to the right (clockwise) until the chain rests against the bottom side of the guide bar.

While still holding up the guide bar, tighten the retaining nuts (2) with the universal wrench.

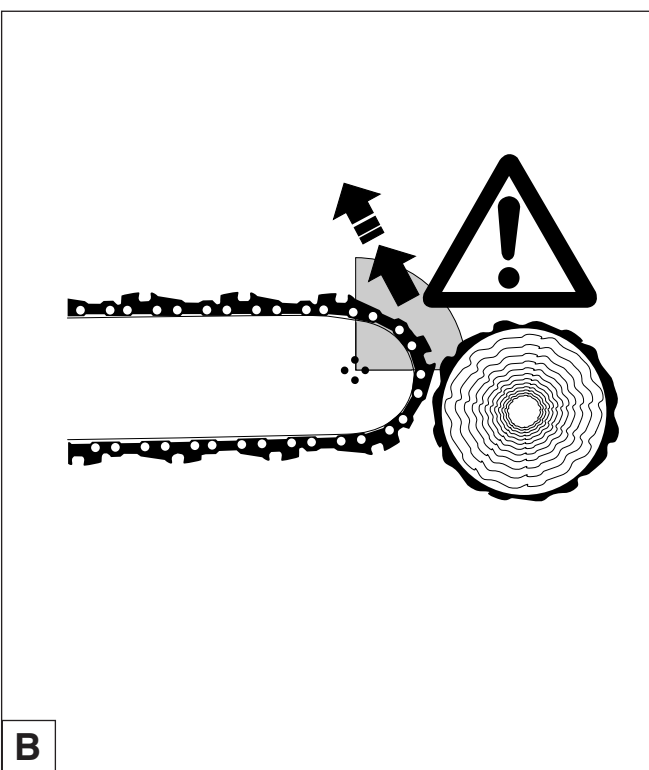

Chain brake

The DCS34, DCS4610 comes with an inertia chain brake as standard equipment. If kickback occurs due to contact of the guide-bar tip with wood (see SAFETY PRECAUTIONS, page 6), the chain brake will stop the chain through inertia if the kickback is sufficiently strong.

The chain will stop within a fraction of a second.

The chain brake is installed to block the saw chain before starting it and to stop it immediately in case of an emergency.

IMPORTANT: NEVER run the saw with the chain brake activated (except for testing, see "Checking the chain brake")! Doing so can very quickly cause extensive engine damage!

ALWAYS release the chain brake before starting the work!

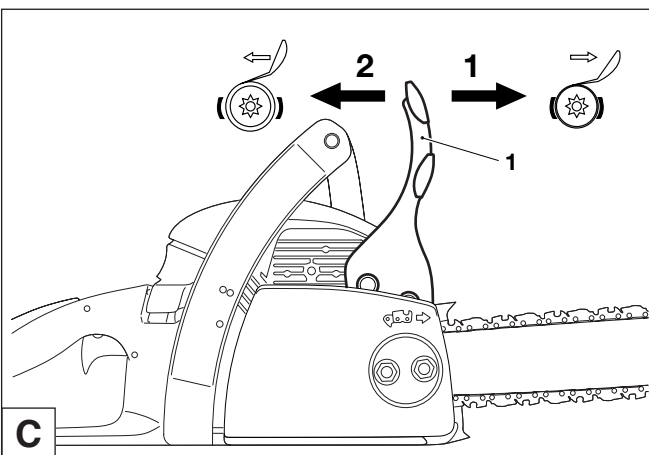

Engaging the chain brake (braking)

If the kickback is strong enough the sudden acceleration of the guide bar combined with the inertia of the hand guard (1) will **automatically** actuate the chain brake.

To engage the chain brake **manually**, simply push the hand guard (1) forward (towards the tip of the saw) with your left hand (arrow 1).

Releasing the chain brake

Pull the hand guard (1) towards you (arrow 2) until you feel it catch. The brake is now released.

Fuel

CAUTION:

This saw is powered by mineral-oil products (gasoline (petrol) and oil).

Be especially careful when handling gasoline (petrol).

Avoid all flame or fire. Do not smoke (explosion hazard).

Fuel mixture

The engine of the chain saw is a high-efficiency two-stroke engine. It runs on a mixture of gasoline and two-stroke engine oil.

The engine is designed for unleaded regular gasoline with a min. octane value of 91 ROZ. In case no such fuel is available, you can use fuel with a higher octane value. This will not affect the engine.

In order to obtain an optimum engine output and to protect your health and the environment use unleaded fuel only.

For lubricating the engine use a two-stroke engine oil (quality grade: JASO FC or ISO EGD), which is added to the fuel. The engine has been designed for use of MAKITA high-performance two-stroke engine oil and a mixture ratio of only 50:1 to protect the environment. In addition, a long service life and reliable operation with a minimum emission of exhaust gases are ensured. MAKITA high-performance two-stroke engine oil is available in the following sizes to suit your individual requirements:

1 l order number 980 008 607

100 ml order number 980 008 606

If MAKITA high-performance two-stroke engine oil is not available, we urgently recommended a mixture ratio of 40:1 with other two-stroke engine oils, as otherwise optimum operation of the engine cannot be guaranteed.



Caution: Do not use ready-mixed fuel from petrol stations.

The correct mixture ratio:

50:1 when using MAKITA high-performance two-stroke engine oil, i. e. mix 50 parts gasoline with 1 part oil.

40:1 when using other two-stroke engine oils, i. e. mix 40 parts gasoline with 1 part oil.

NOTE:

For preparing the fuel-oil mixture first mix the entire oil quantity with half of the fuel required, then add the remaining fuel. Thoroughly shake the mixture before filling it into the chain saw tank.



| Gasoline | 50:1 | 40:1 |
|-----------------------------------|---------------------|---------------------|
| | | |
| 1000 cm ³ (1 litre) | 20 cm ³ | 25 cm ³ |
| 5000 cm ³ (5 litres) | 100 cm ³ | 125 cm ³ |
| 10000 cm ³ (10 litres) | 200 cm ³ | 250 cm ³ |

It is not wise to add more engine oil than specified to ensure safe operation. This will only result in a higher production of combustion residues which will pollute the environment and clog the exhaust channel in the cylinder as well as the muffler. In addition, fuel consumption will rise and performance will decrease.

The Storage of Fuel

Fuels have a limited storage life. Fuel and fuel mixtures age through evaporation, especially at high temperatures. Aged fuel and fuel mixtures can cause starting problems and damage the engine. Purchase only that amount of fuel, which will be consumed over the next few months. At high temperatures, once fuel has been mixed it should be used up in 6-8 weeks.

Store fuel only in proper containers, in dry, cool, secure locations!

AVOID SKIN AND EYE CONTACT

Mineral oil products degrease your skin. If your skin comes in contact with these substances repeatedly and for an extended period of time, it will desiccate. Various skin diseases may result. In addition, allergic reactions are known to occur.

Eyes can be irritated by contact with oil. If oil comes into your eyes, immediately wash them with clear water.

If your eyes are still irritated, see a doctor immediately!

D

Chain oil



Use an oil with adhesive additive for lubricating the chain and guide bar. The adhesive additive prevents the oil from being flung off the chain too quickly.

We recommend the use of chain oil which is bio-degradable in order to protect the environment. The use of bio-degradable oil may even be required by local regulations.

The chain oil BIOTOP sold by MAKITA is made of special vegetable oils and is 100% bio-degradable. BIOTOP has been granted the „blue angel“ (Blauer Umweltschutz-Engel) for being particularly environment-friendly (RAL UZ 48).



BIOTOP chain oil is available in the following sizes:

1 l order number 980 008 610

5 l order number 980 008 611

Bio-degradable oil is stable only for a limited period of time. It should be used within 2 years from the date of manufacture (printed on the container).

E

Important note on bio-degradable chain oils:

If you are not planning to use the saw again for an extended period of time, empty the oil tank and put in a small amount of regular **engine oil** (SAE 30), and then run the saw for a time. This is necessary to flush out all remaining bio-degradable oil from the oil tank, oil-feed system, chain and guide bar, as many such oils tend to leave sticky residues over time, which can cause damage

to the oil pump or other parts.

The next time you use the saw, fill the tank with BIOTOP chain oil again. In case of damage caused by using waste oil or inappropriate chain oil the product guarantee will be null and void.

Your salesman will inform you about the use of chain oil.

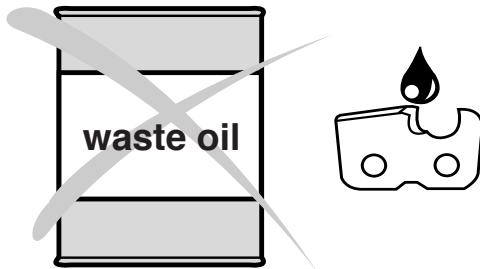

NEVER USE WASTE OIL

Waste oil is very dangerous for the environment.

Waste oil contains high amounts of carcinogenic substances. Residues in waste oil result in a high degree of wear and tear at the oil pump and the sawing device.

In case of damage caused by using waste oil or inappropriate chain oil the product guarantee will be null and void.

Your salesman will inform you about the use of chain oil.

AVOID SKIN AND EYE CONTACT

Mineral oil products degrease your skin. If your skin comes in contact with these substances repeatedly and for an extended period of time, it will desiccate. Various skin diseases may result. In addition, allergic reactions are known to occur.

Eyes can be irritated by contact with oil. If oil comes into your eyes, immediately wash them with clear water.

If your eyes are still irritated, see a doctor immediately!

A



Refuelling



FOLLOW THE SAFETY PRECAUTIONS!

Be careful and cautious when handling fuels.

The engine must be switched off!

Thoroughly clean the area around the caps, to prevent dirt from getting into the fuel or oil tank.

Unscrew the cap and fill the tank with fuel (fuel/oil mixture) or chain oil as the case may be. Fill up to the bottom edge of the filler neck. Be careful not to spill fuel or chain oil!

Tightly screw on the cap.

Clean screw cap and tank after refuelling.

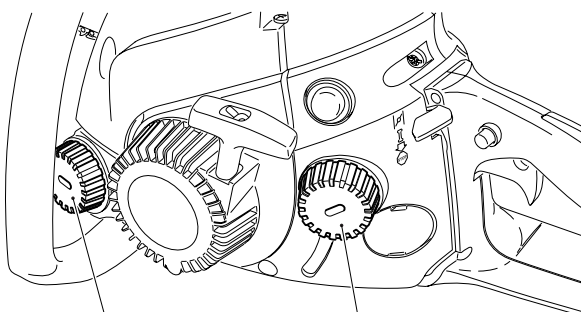

Lubricating the chain



During operation there must always be sufficient chain oil in the chain-oil tank to provide good chain lubrication. One filling is sufficient for about one half-hour of continuous operation. While working make sure there is enough chain oil in the tank. If necessary, add oil. **The engine must be switched off!**

B

Checking the chain lubrication

Never work with the chain saw without sufficient chain lubrication. Otherwise the service life of the chain and guide bar will be reduced.

Before starting work check the oil level in the tank and the oil feed.

Check the oil feed rate as described below:

Start the chain saw (see „Starting the engine“).

Hold the running chain saw approx. 15 cm above a trunk or the ground (use an appropriate base).

If the lubrication is sufficient, you will see a light oil trace because oil will be flung off the sawing device. Pay attention to the direction the wind is blowing and avoid unnecessary exposure to the oil spray!

Note:

After the saw has been turned off it is normal for residual chain oil to drip from the oil feed system, the guide bar and the chain for a time. This does not constitute a defect!

Place the saw on a suitable surface.

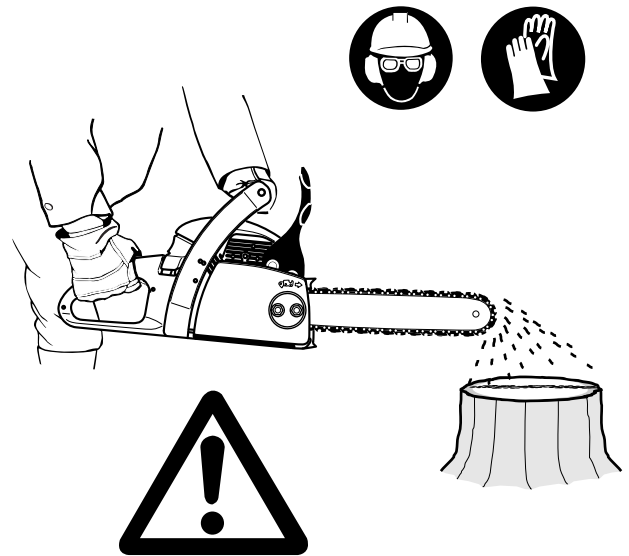

C

To ensure troublefree operation of the oil pump the oil guide groove at the crankcase (1) and the oil inlet bore in the guide bar (2) must be cleaned regularly.

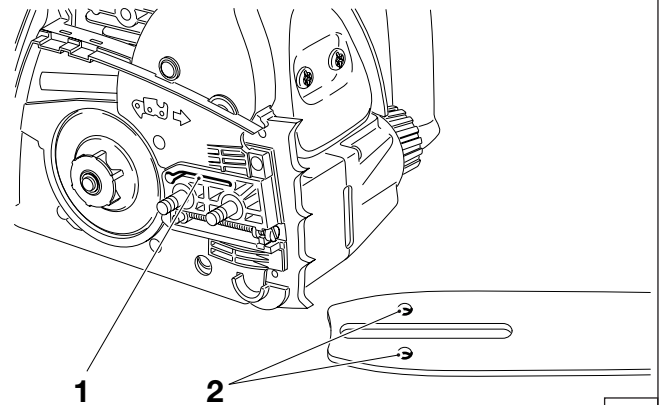

D

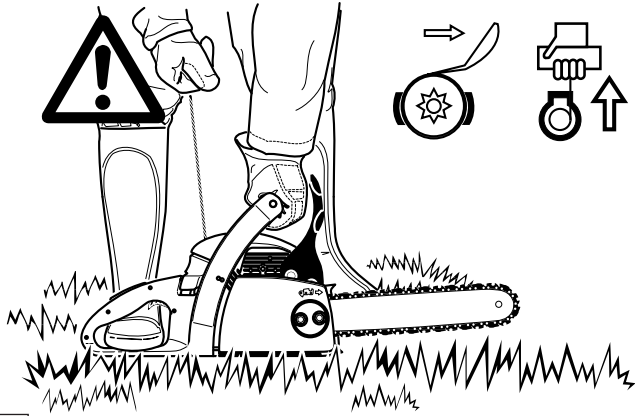

A

Starting the engine

Start the chain saw only after having assembled it completely and inspected!

Move at least 10 feet (3 m) away from the place where you fuelled the saw.

Make sure you have a good footing, and place the saw on the ground in such a way that the chain is not touching anything.

Engage the chain brake (lock).

Hold the tubular handle tightly with one hand and press the chain saw to the ground.

Steady the rear handle by standing in the hand guard.

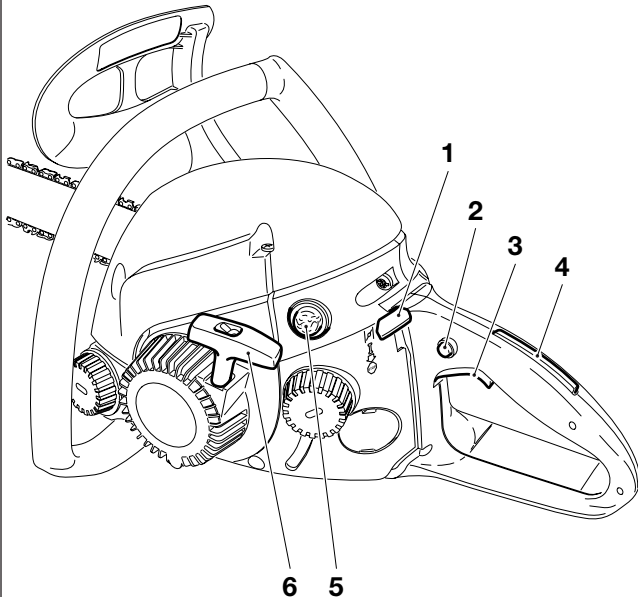

B

Cold start:



Prime the fuel pump (5) by pressing it several times until you can see fuel in the pump.

Move the combination switch (1) up (choke position).

Grasp handle (hand pressure actuates the grip throttle lever lock (4)).

Push the throttle (3) in all the way and hold it.

Press the throttle lock (2) and release the throttle (3) (the throttle lock will hold the throttle at half-throttle position).

Slowly pull out the starter cable (6) until you notice resistance (the piston is positioned before the top dead centre).

Now pull the starter cable with a fast and forceful movement until **you hear the first ignition**.

CAUTION: Do not pull out the starter cable more than approx. 50 cm, and lead it back by hand.

When you hear the first ignition, put the combination switch (1) in position „I“ and pull the starter cable again.

As soon as the engine is running, press the throttle (3) to release the half-throttle lock (2), allowing the engine to idle.

CAUTION: As soon as the engine is started it must be put in idle to prevent the chain brake from being damaged.

Now release the chain brake.



Warm start:

As described above for cold starting, but without using the choke position.

Stopping the engine (only for DCS34)

Push the combination switch (1) down to position .

Stopping the engine (only for DCS4610)

Press the combination switch (1) down in direction .

NOTE: After being pressed down, the DCS4610 combination switch will revert to the „I“ position again. The engine is switched off, but can be turned on again without moving the combination switch.

IMPORTANT: To cut off the ignition current of the DCS4610, push the combination switch all the way down past the resistance point ().

Checking the chain brake

Do not work with the chain saw without first checking the chain brake!

Start the engine as described (make sure you have a good footing, and place the chain saw on the ground in such a way that the guide bar is free of contact).

Grasp the tubular handle firmly with one hand and hold the grip with the other.

With the engine running at moderate speed, press the hand guard (7) in the direction of the arrow with the back of your hand until the chain brake engages. The chain should stop immediately.

Immediately release the throttle and release the chain brake.

IMPORTANT: If the chain does not stop immediately when you test the chain brake, do NOT use the chain saw. Take the chain saw to a MAKITA service center.

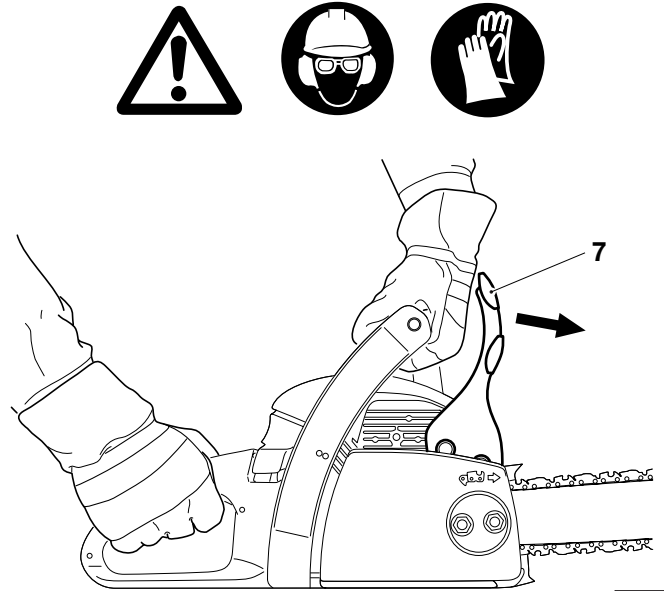

Adjusting the carburetor

IMPORTANT: Carburetor adjustment may be done only by a MAKITA service centre!

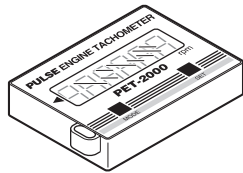

Do not undertake adjustments to the adjusting screws (H) and (L) without a tachometer! Improper adjustment can lead to engine damage!

The adjusting screws (H) and (L) are factory set almost all the way out (turned counterclockwise).

A tachometer is necessary to adjust the adjusting screws (H) and (L), because exceeding the permissible maximum speed leads to overheating and under-lubrication. This can damage the engine!

The only user-adjustable setting is the idle adjusting screw (9). If the blade rotates in idle (without the throttle pressed), it is absolutely necessary to correct the idle speed before using the tool!

Do not adjust the idle speed until the machine has been completely assembled and checked!

Adjust the idle speed only with the engine warm, a clean air filter, and properly installed cutting tool.

Use a screwdriver (blade width 4 mm, part No. 944 340 001) to adjust the screw.

Setting the idle speed

Turn out the idle adjusting screw (9) (counterclockwise): Idle speed drops.

Turn in the idle adjusting screw (9) (clockwise): Idle speed goes up.

Caution: If after this adjustment the cutting tool still rotates during idle, do NOT work with the unit! Take it to a MAKITA service centre!

Note: Carburetor adjustment is necessary for optimum engine performance, for safer and more economical operation.

In order to comply with new emissions legislation, limits have been placed on the carburetor adjusting screws (H) and (L). This limitation (to about 180 degrees) prevents an excessively rich mixture. On some models the (H) screw is also sealed. This ensures compliance with emissions rules as well as optimum engine performance and economical fuel consumption.

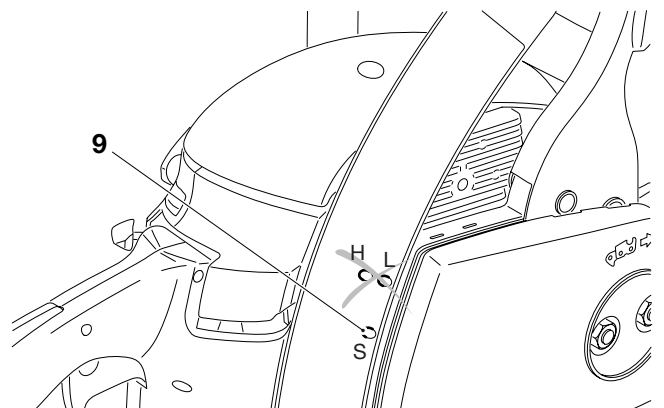
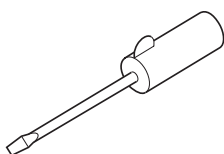

MAINTENANCE

Sharpening the saw chain



CAUTION: Before doing any work on the guide bar or chain, always switch off the engine and pull the plug cap off the spark plug (see „Replacing the spark plug“). Always wear protective gloves!

The chain needs sharpening when:

The sawdust produced when sawing damp wood looks like wood flour.

The chain penetrates the wood only under great pressure.

The cutting edge is visibly damaged.

The saw is pulled to the left or right when sawing. This is caused by uneven sharpening of the chain.

Important: Sharpen frequently, but without removing too much metal!

Generally, 2 or 3 strokes of the file will be enough.

Have the chain resharpened at a service centre when you have already sharpened it yourself several times.

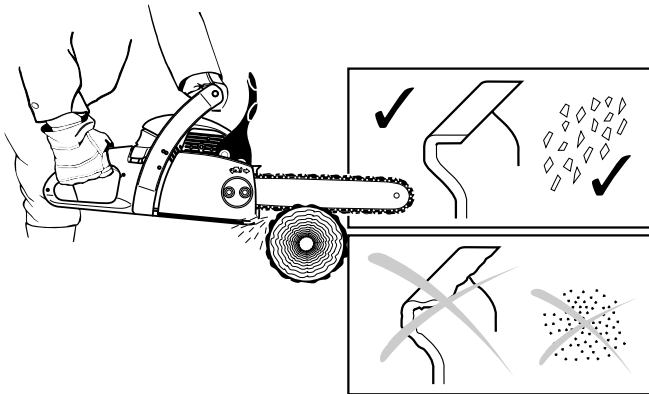

A

Proper sharpening:

CAUTION: Use only chains and guide bars designed for this saw (see the Extract from the spare-parts list)!

All cutters must be of the same length (dimension a). Cutters with different lengths result in rough running of the chain and can cause cracks in the chain.

Minimum cutter length is 3 mm (0.11“). Do not resharpen the chain when the minimum cutter length has been reached; at this point, the chain must be replaced (see the Extract from the spare-parts list and „Replacing the chain“).

The depth of the cut is determined by the difference in height between the depth limiter (round nose) and the cutting edge.

The best results are obtained with a depth-limiter depth of 0.64 mm (.025“).

CAUTION: Excessive depth increases the risk of kickback!

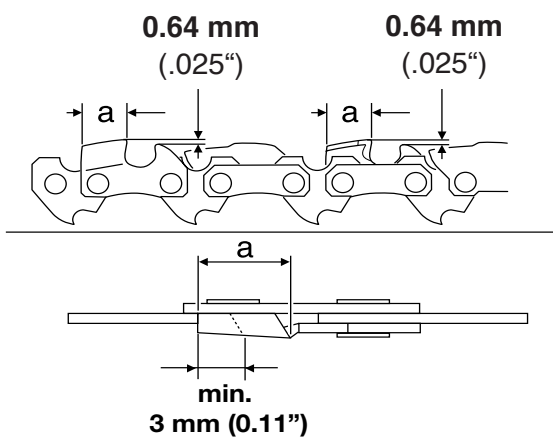
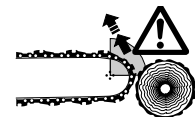

B

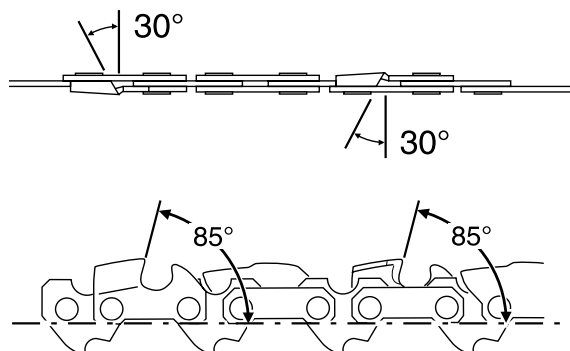

All cutters must be sharpened to the same angle, 30°. Different angles result in a roughly, irregularly running chain, increase wear and tear and cause chain beakage.

The 85° front rake of the cutter results from the cut depth of the round file. If the proper file is used in the right manner, the correct front rake will be obtained automatically.

C

Files and how to work with them

Sharpen using a special file holder with a saw chain round file dia. 4.0 mm. Normal round files are not appropriate for this work. See „Accessories“ for the order number.

The file should cut only when pushed forwards (arrow). Lift the file when leading it backwards.

First sharpen the shortest cutter. The length of this cutter is then the standard for all other cutters of the chain.

Always guide the file horizontally (90° to the guide bar).

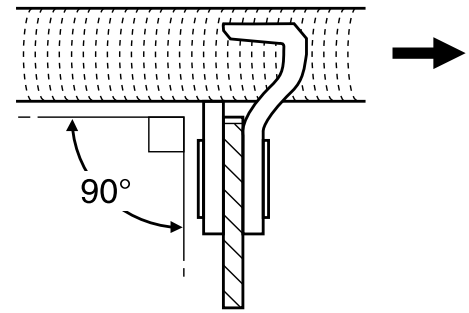

D

The file holder makes file guidance easier. It is marked for the correct 30° sharpening angle (keep the marks parallel with the chain when filing, see illustration) and limits the cut depth to the correct 4/5 of the file diameter. See „Accessories“ for the order number.

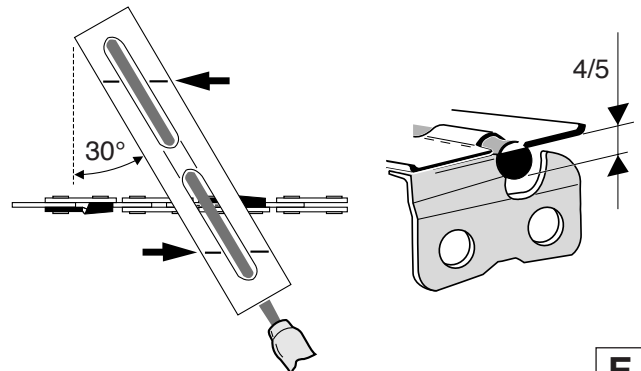

E

After having sharpened the chain, the height of the depth limiter must be checked by means of a chain gauge. See „Accessories“ for the order number.

Correct even the smallest excess height (13) with a special flat file. See „Accessories“ for the order number.

Round off the front of the depth limiter (14).

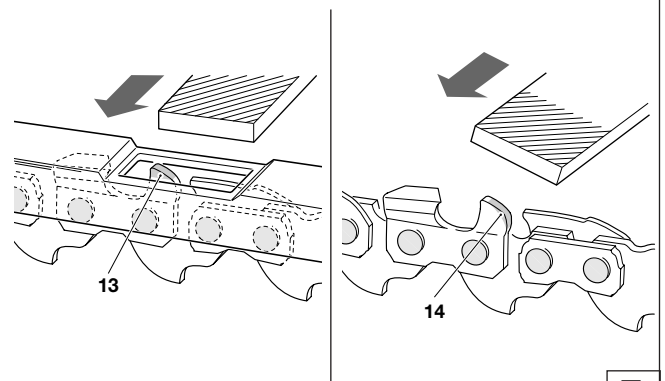

F



Cleaning the brake band and sprocket interior

CAUTION: Before doing any work on the guide bar or chain, **always** switch off the engine and pull the plug cap off the spark plug (see „Replacing the spark plug“). **Always wear protective gloves!**

CAUTION: Start the chain saw only after having assembled it completely and inspected!

Remove the sprocket guard (4) (See „PUTTING INTO OPERATION“ figs. A and B) and clean the sprocket interior with a brush.

Turn the chain tightener screw (5) to the left (counterclockwise) until you feel resistance.

Remove the chain (3) and guide bar (2).

NOTE:

Make sure that no residue or contaminants remain in the oil guide groove (1) and the chain tightener (6).

For replacing the guide bar, chain, and sprocket see „PUTTING INTO OPERATION“.

NOTE:

The chain brake is a very important safety device and like any other component subject to normal wear and tear.

Regular inspection and maintenance are important for your own safety and must be done by a MAKITA service center.

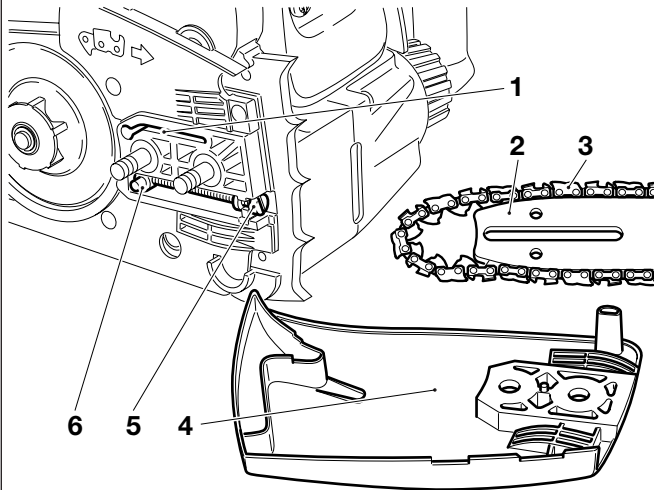

SERVICE

A

Cleaning the guide bar, lubricating the sprocket nose

CAUTION: Protective gloves must be worn.

Regularly inspect the bearing surfaces of the guide bar for damage, and clean them with a suitable tool.

If the saw is used intensively it will be necessary to lubricate the return sprocket bearings regularly (once a week). To do this, first **thoroughly** clean the 2 mm hole at the tip of the guide bar, and then press in a small amount of multi-purpose grease.

Multi-purpose grease and grease guns are available as accessories.

Multi-purpose grease (order no. 944 360 000)

Grease gun (order no. 944 350 000)

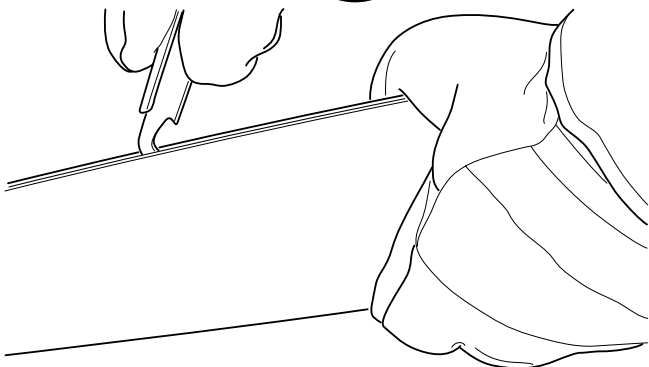

B

Replacing the saw chain

CAUTION: Use only chains and guide bars designed for this saw (see the Extract from the spare-parts list)!

Check the sprocket (7) before mounting a new chain.

Remove the sprocket guard (See „PUTTING INTO OPERATION“ figs. A - H).

CAUTION:

Worn out sprockets (8) may damage the new chain and must therefore be replaced.



SERVICE

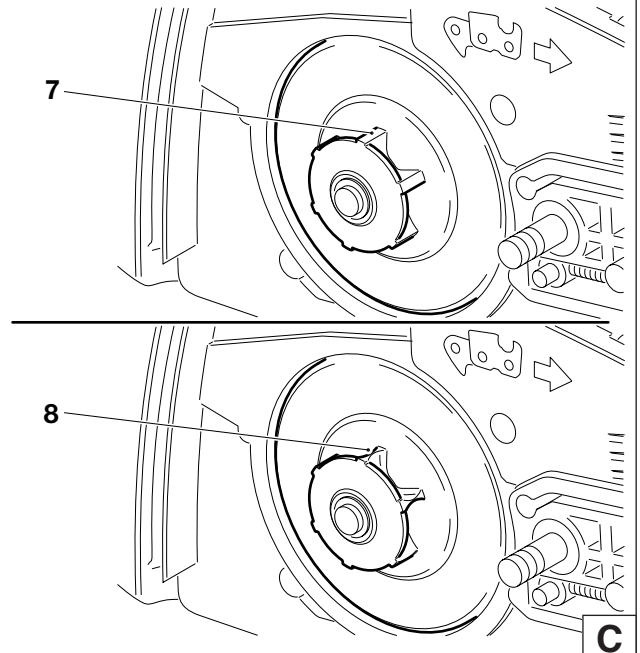

Replacing the suction head

The felt filter (9) of the suction head can become clogged. It is recommended to replace the suction head once every three months in order to ensure unimpeded fuel flow to the carburetor.

To remove the suction head for replacement, pull it out through the tank filler neck using a piece of wire bent at one end to form a hook.

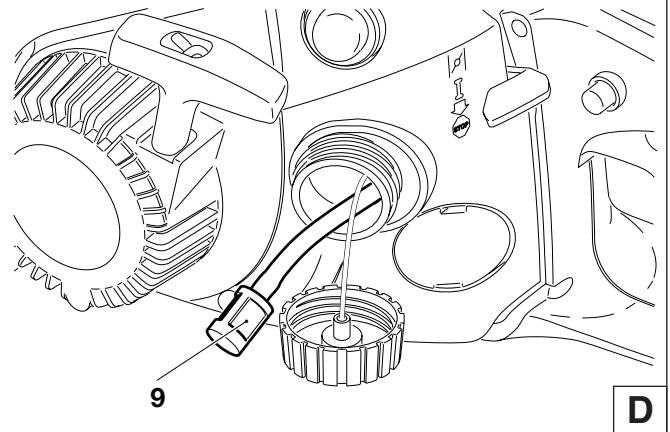

Cleaning the air filter



Remove the filter cover (11) (3 screws (10)).

Remove the air filter (12).

CAUTION:

Cover the intake opening with a cloth to prevent dirt particles from getting into the carburetor.

CAUTION:

To prevent injury to the eyes, do NOT blow out dirt particles! Do not use fuel to clean the air filter.

If the filter is very dirty, clean it in lukewarm water with dish-washing detergent.

Let the air filter **dry completely**.

If the filter is very dirty, clean it frequently (several times a day), because only a clean air filter provides full engine power.

CAUTION:

Replace damaged air filters immediately.

Pieces of cloth or large dirt particles can destroy the engine!

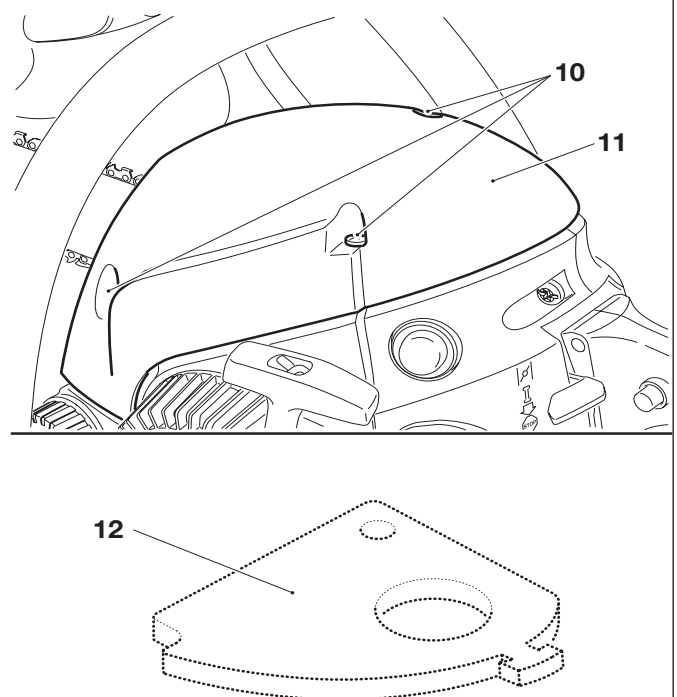

Replacing the spark plug



CAUTION:

Do not touch the spark plug or plug cap if the engine is running (high voltage).

Switch off the engine before starting any maintenance work. A hot engine can cause burns. Wear protective gloves!

The spark plug must be replaced in case of damage to the insulator, electrode erosion (burn) or if the electrodes are very dirty or oily.

Remove the cover (see „Cleaning the air filter“).

Pull the plug cap (1) off the spark plug. Use only the combination wrench supplied with the saw to remove the spark plug.

Electrode gap

The electrode gap must be 0.5 mm.

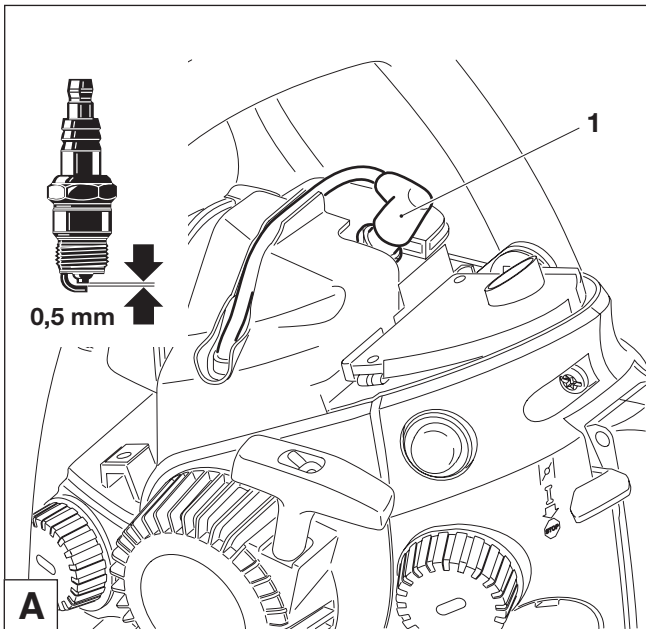

Checking the ignition spark

Press the loosened spark plug (2) with the ignition cable firmly connected against the cylinder using insulated pliers (not near the spark plug opening).

Press the combination switch (3) in the „I“ position.

Pull the starter cable hard.

If the function is correct, an ignition spark must be visible near the electrodes.

CAUTION: Use only the following spark plugs:

- NGK BPMR 7A

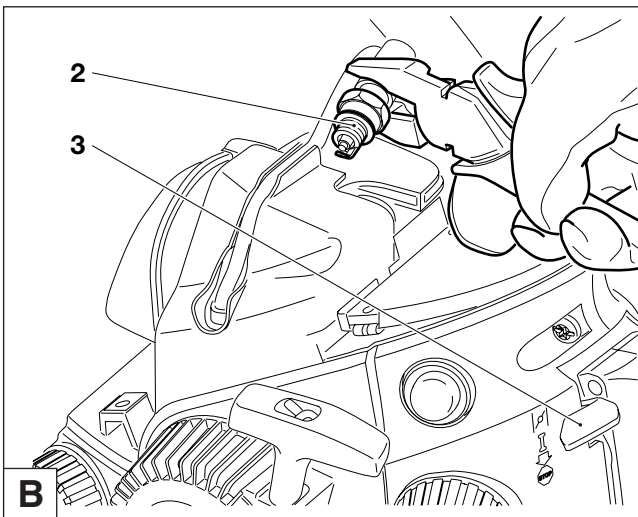

Instructions for periodic maintenance

To ensure long life, prevent damage and ensure the full functioning of the safety features the following maintenance must be performed regularly. Guarantee claims can be recognized only if this work is performed regularly and properly. Failure to perform the prescribed maintenance work can lead to accidents!

The user of the chain saw must not perform maintenance work which is not described in the instruction manual. All such work must be carried out by a MAKITA service centre.

| | | | Page |
|--------------------------|---|--|-------------|
| General | Chain saw | Clean exterior, check for damage. In case of damage, have repaired by a qualified service centre immediately | 18-19 |
| | Saw chain | Sharpen regularly, replace in good time | |
| | Chain brake | Have inspected regularly at an authorized service centre | 12, 20 |
| | Guide bar | Turn over to ensure even wear of bearing surfaces Replace in good time | |
| | Starter cable | Check for damage. In case of damage, have repaired by a qualified service centre immediately | |
| Before each start | Saw chain | Inspect for damage and sharpness Check chain tension | 18-19 12 |
| | Guide bar | Check for damage | |
| | Chain lubrication | Functional check | 15 |
| | Chain brake | Functional check | 17 |
| | Combination switch, Safety locking button, Throttle lever | Functional check | 16 |
| | Fuel/oil tank cap | Check for tightness | |
| Every day | Air filter | Clean | 21 |
| | Guide bar | Check for damage, clean oil intake bore | 20 |
| | Guide bar support | Clean, in particular the oil guide groove | 15, 20 |
| | Idle speed | Check (chain must not run) | 17 |
| Every week | Fan housing | Clean to ensure proper air cooling | 9 |
| | Spark plug | Check and replace if necessary | 22 |
| | Muffler | Check tightness of mounting | 9 |
| | Chain catch | Check | 11 |
| | Screws and nuts | Check their condition and that they are firmly secured. | |
| Every 3 months | Suction head | Replace | 21 |
| | Fuel, oil tanks | Clean | |
| Annually | Chain saw | Check at an authorized service centre | |
| Storage | Chain saw | Clean exterior, check for damage. In case of damage, have repaired by a qualified service centre immediately | 20 |
| | Chain, guide bar | Demount, clean and oil slightly Clean the guide groove of the guide bar | |
| | Fuel, oil tanks | Empty and clean | |
| | Carburetor | Run empty | |

Service, spare parts and guarantee

Maintenance and repair

The maintenance and repair of modern engines as well as all safety devices require qualified technical training and a special workshop equipped with special tools and testing devices.

We therefore recommend that you consult a MAKITA service centre for all work not described in this instruction manual. The MAKITA service centres have all the necessary equipment and skilled and experienced personnel, who can work out cost-effective solutions and advise you in all matters.

To find your local distributor, please visit www.makita-outdoor.com

Spare parts

Reliable long-term operation, as well as the safety of your chain saw, depend among other things on the quality of the spare parts used. Use only original MAKITA parts, marked



Only original spare parts and accessories guarantee the highest quality in material, dimensions, functioning and safety.

Original spare parts and accessories can be obtained from your local dealer. He will also have the spare part lists to determine the required spare part numbers, and will be constantly informed about the latest improvements and spare part innovations. To find your local distributor, please visit www.makita-outdoor.com

Please bear in mind that if parts other than original MAKITA spare parts are used, this will automatically invalidate the MAKITA product guarantee.

Guarantee

MAKITA guarantees the highest quality and will therefore reimburse all costs for repair by replacement of damaged parts resulting from material or production faults occurring within the guarantee period after purchase. Please note that in some countries particular guarantee conditions may exist. If you have any questions, please contact your salesman, who is responsible for the guarantee of the product.

Please note that we cannot accept any responsibility for damage caused by:

- Disregard of the instruction manual.
- Non-performance of the required maintenance and cleaning.
- Incorrect carburetor adjustment.
- Normal wear and tear.
- Obvious overloading due to permanent exceeding of the upper performance limits.
- Use of guide bars and chains which have not been approved.
- Use of guide bar and chain lengths which have not been approved.
- Use of force, improper use, misuse or accidents.
- Damage from overheating due to dirt on the fan housing.
- Work on the chain saw by unskilled persons or inappropriate repairs.
- Use of unsuitable spare parts or parts which are not original MAKITA parts, insofar as they have caused the damage.
- Use of unsuitable or old oil.
- Damage related to conditions arising from lease or rent contracts.
- Damages caused by disregarding loose outer bolted connections.

Cleaning, servicing and adjustment work is not covered by the guarantee. All repairs covered by the guarantee must be performed by a MAKITA service centre.

Troubleshooting

| Malfunction | System | Observation | Cause |
|---|--|---------------------------------------|---|
| Chain does not run | Chain brake | Engine runs | Chain brake actuated. |
| Engine does not start or only with difficulty | Ignition system | Ignition spark No ignition spark | Malfunction in fuel supply system, compression system, mechanical malfunction. Switch on STOP, fault or short-circuit in the wiring, plug cap or spark plug defective. Choke in wrong position, carburetor defective, suction head dirty, fuel line bent or interrupted. Cylinder base packing ring defective, radial shaft packings defective, cylinder or piston rings defective Spark plug does not seal. Spring in starter broken, broken parts inside the engine. |
| | Fuel supply | Fuel tank is filled | |
| | Compression system | Inside Outside | |
| | Mechanical malfunction | Starter does not engage | |
| Warm start difficulties | Carburetor | Fuel tank is filled Ignition spark | Wrong carburetor adjustment. |
| Engine starts, but dies immediately | Fuel supply | Fuel tank is filled | Wrong idling adjustment, suction head or carburetor dirty. Tank venting defective, fuel line interrupted, cable defective, combination switch defective. |
| Insufficient power | Several systems may be involved simultaneously | Engine is idling | Air filter dirty, wrong carburetor adjustment, muffler clogged, exhaust channel in cylinder clogged. |
| No chain lubrication | Oil tank/pump | No oil on the chain | Oil tank empty. Oil guide groove dirty. |

Extract from the spare parts list

Use only original MAKITA parts.

For repairs and replacement of other parts, see your MAKITA service center.

DCS34
DCS4610



| Pos. | MAKITA-No. | Qty. | Denomination |
|------|-------------|------|-------------------------------|
| 1 | 442 035 661 | 1 | Sprocket nose bar 35 cm (14") |
| 2 | 528 092 652 | 1 | Saw chain 3/8" for 35 cm |
| 1 | 442 040 661 | 1 | Sprocket nose bar 40 cm (16") |
| 2 | 528 092 656 | 1 | Saw chain 3/8" for 40 cm |
| 3 | 952 010 630 | 1 | Chain protection for 30-35 cm |
| | 952 010 640 | 1 | Chain protection for 40 cm |
| 4 | 036 213 651 | 1 | Sprocket guard, cpl. |
| 5 | 923 208 004 | 2 | Hexagonal nut M8 |
| 6 | 941 719 131 | 1 | Universal wrench SW 19/13 |
| 7 | 963 601 380 | 1 | Suction head |
| 8 | 965 603 021 | 1 | Spark plug |
| 9 | 036 173 011 | 1 | Air filter |
| 10 | 010 114 061 | 1 | Fuel-/oil tank cap, cpl. |

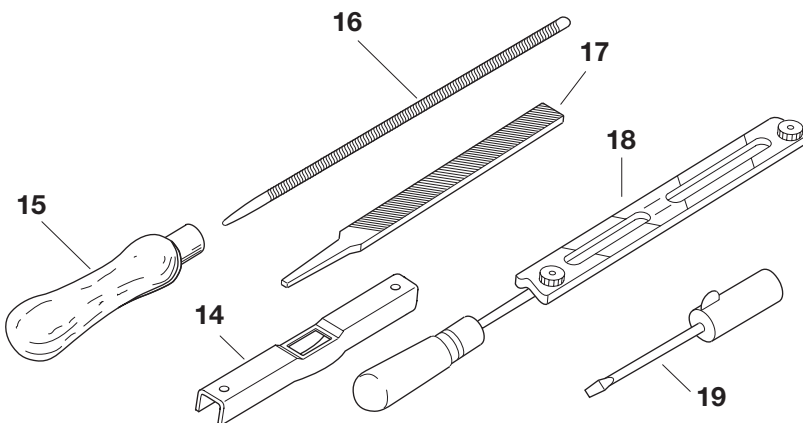
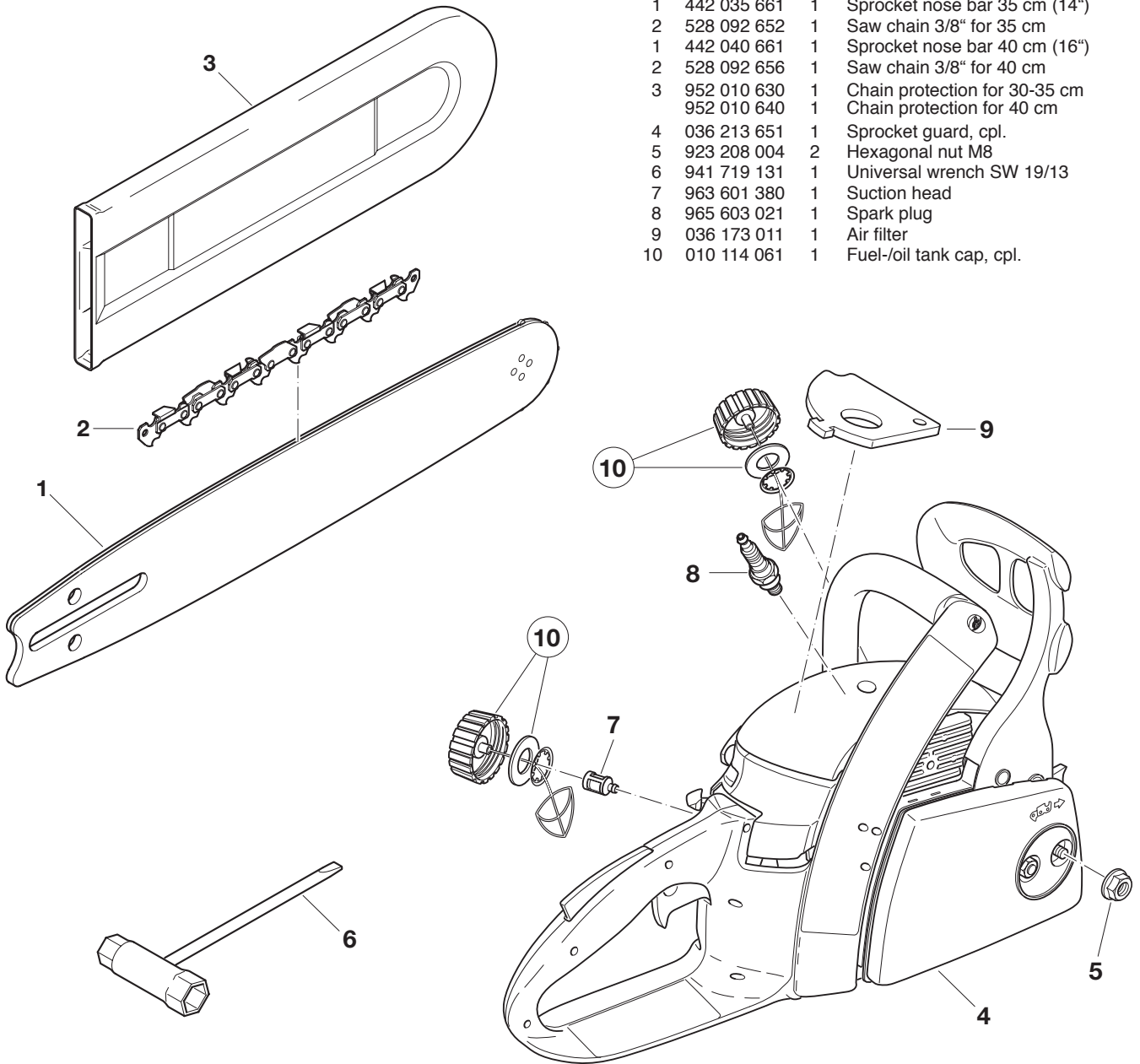

Accessories (not delivered with the chain saw)

| | | | |
|----|-------------|---|---|
| 14 | 953 100 090 | 1 | Chain gauge |
| 15 | 953 004 010 | 1 | File handle |
| 16 | 953 003 090 | 1 | Round file, dia. 4.0 mm |
| 17 | 953 003 060 | 1 | Flat file |
| 18 | 953 030 010 | 1 | File holder (with 4.0 mm dia. round file) |
| 19 | 944 340 001 | 1 | Carburetor screwdriver |
| - | 980 008 607 | 1 | Two-stroke engine oil (1 l) |
| - | 980 008 606 | 1 | Two-stroke engine oil (100 ml) |
| - | 980 008 610 | 1 | BIOTOP chain oil (1 l) |
| - | 980 008 611 | 1 | BIOTOP chain oil (5 l) |
| - | 949 000 035 | 1 | Combined can (for 5 l fuel, 2.5 l chain oil) |

EU Conformity Declaration

The undersigned, Tamiro Kishima and Rainer Bergfeld, as authorized by DOLMAR GmbH, declare that the MAKITA machines,

Type: 036/037 **EU prototype test certificate No.**

DCS34 **M6 08 01 24243 082**

DCS4610 **M6 08 01 24243 082**

manufactured by DOLMAR GmbH, Jenfelder Str. 38, 22045 Hamburg, Germany, conforms to the basic safety and health requirements of the applicable EU guidelines:

EU Machine Directive 98/37/ EG,

EU EMC Directive 89/336/ EWG (modified by 91/263/ EWG, 92/31/EWG and 93/68/ EWG),

Noise emission 2000/14/EG.

Starting on 29 Dec. 2009, Directive 2006/42/EG will come into force, replacing Directive 98/37/EG. This product meets the requirements of the new Directive.

The most important standards applied to properly meet the requirements of the above EU Directive were: EN 11681-1, EN ISO 14982, CISPR 12.

The conformity assessment procedure 2000/14/EG was performed per Annex V. The measured sound power level (Lwa) is 111 dB(A). The guaranteed sound power level (Ld) is 112 dB(A).

The EU Type-Examination was performed by: TÜV Product Service GmbH, Zertifizierungsstelle, Ridlerstraße 31, D-80339 München.

The technical documentation is on file at DOLMAR GmbH, Jenfelder Strasse 38, Department FZ, 22045 Hamburg, Germany.

Hamburg, 10.1. 2008

For DOLMAR GmbH



Tamiro Kishima
Managing Director



Rainer Bergfeld
Managing Director

To find your local distributor, please
visit www.makita-outdoor.com



Makita Werkzeug GmbH
Postfach 70 04 20
D-22004 Hamburg
Germany

Specifications subject to change without notice

Form: 995 707 676 (1.08 GB)