

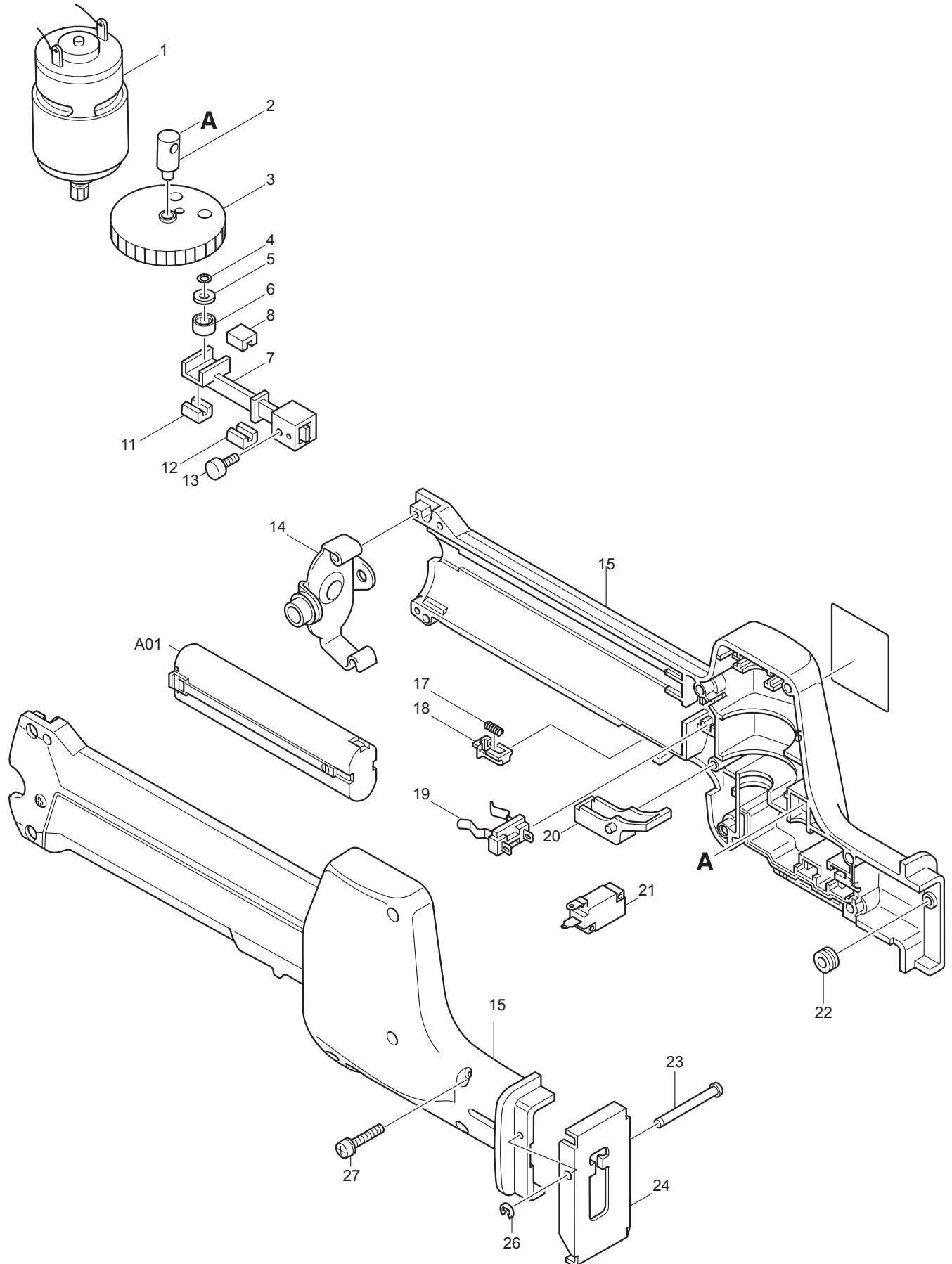

03 - 2010
4390D / 4390DW
CORDLESS RECIPRO SAW



Item No.	Type	Sub	Part No.	Description (*see Service changes on the bottom)	Qty	Unit
1			629581-1	* DC MOTOR 9.6V	1	PC.
		INC.	221882-9	* SPUR GEAR 15	1	PC.
2			152272-4	SUPPORTER COMPLETE	1	PC.
3			153202-8	* GEAR COMPLETE	1	PC.
4			253307-5	THIN WASHER 4	3	PC.
5			253874-0	FLAT WASHER 4	1	PC.
6			212014-9	NEEDLE BEARING 407	1	PC.
7			154401-5	* SLIDER	1	PC.
		INC.	256672-1	PIN 2	1	PC.
		INC.	313057-5	BLADE CLAMP	1	PC.
		INC.	258017-9	SPRING PIN 1.5-10	1	PC.
		INC.		Item No. 9		
8			214020-0	PLANE BEARING 3	1	PC.
9			443063-7	* FELT	1	PC.
10			344979-8	* BASE HOLDER (OLD# 334032-8 - N/L/A) (OLD)	1	PC.
11			214020-0	PLANE BEARING 3	1	PC.
12			214020-0	PLANE BEARING 3	1	PC.
13			922107-1	HEX. SOCKET HEAD BOLT M4X8	1	PC.
14	1		163157-9	SET PLATE		
	2		342833-0	SET PLATE	1	PC.
15			182406-5	* HOUSING SET	1	SET
17			231390-2	COMPRESSION SPRING 3	1	PC.
18			414169-8	LOCK-OFF LEVER	1	PC.
19			643909-9	BATTERY HOLDER	1	PC.
20			410972-5	TRIGGER	1	PC.
21	1		651899-2	SWITCH	1	PC.
	2		651866-7	SWITCH	1	PC.
22			322099-8	ROLLER	1	PC.
23			256654-3	PIN 4	1	PC.
24			343875-7	* SHOE	1	PC.
26			961017-7	STOP RING E-3	1	PC.
27			911143-2	PAN HEAD SCREW M4X22	8	PC.
100			655000-B	PLUG (FOR CAR LIGHTER)	1	PC.
<u>ACCESSORIES</u>				- See catalogue or visit www.makita.ca for other optional accessories -		
A01			632007-4	9.6V NI-CAD BATTERY 9000	1	PC.
A02			783201-2	HEX WRENCH 3	1	PC.
A03			414938-7	BATTERY COVER	1	PC.
A04			DC1414	CHARGER DC1414	1	PC.
A05			792541-7	RECIPRO SAW BLADE #78, 5PC/SET (OLD# 792543-3)	1	PC.
			792542-5	RECIPRO SAW BLADE #71, 5PC/SET	1	PC.
A06			824285-2	PLASTIC CARRYING CASE	1	PC.

SERVICE CHANGES

1. Changes on Motor Housing, Gear, Slider, Shoe etc.

Item No.	Description	Type 1	Type 2	Type 3	Type 4
1	Motor D.C 9V	629544-7 (N/LA)	629578-0 (N/LA)	629581-1	
	Spur Gear (Component of Item 1)	221920-7 (N/LA)		221882-9	
15	Housing Set	410995-3 (R) (N/LA)	414344-6 (R) (N/LA)		182406-5
		410996-1 (L) (N/LA)	414345-4 (L) (N/LA)		
3	Gear Com.	153157-7 (N/LA)		153202-8	
24	Shoe	343456-7			343875-7
7	Slider Com.	164774-8 (Slider)			154401-5
9	Felt	443063-7			
10	Base Holder	344979-8 (or 334032-8)			----

Above parts are completely interchangeable as a set.

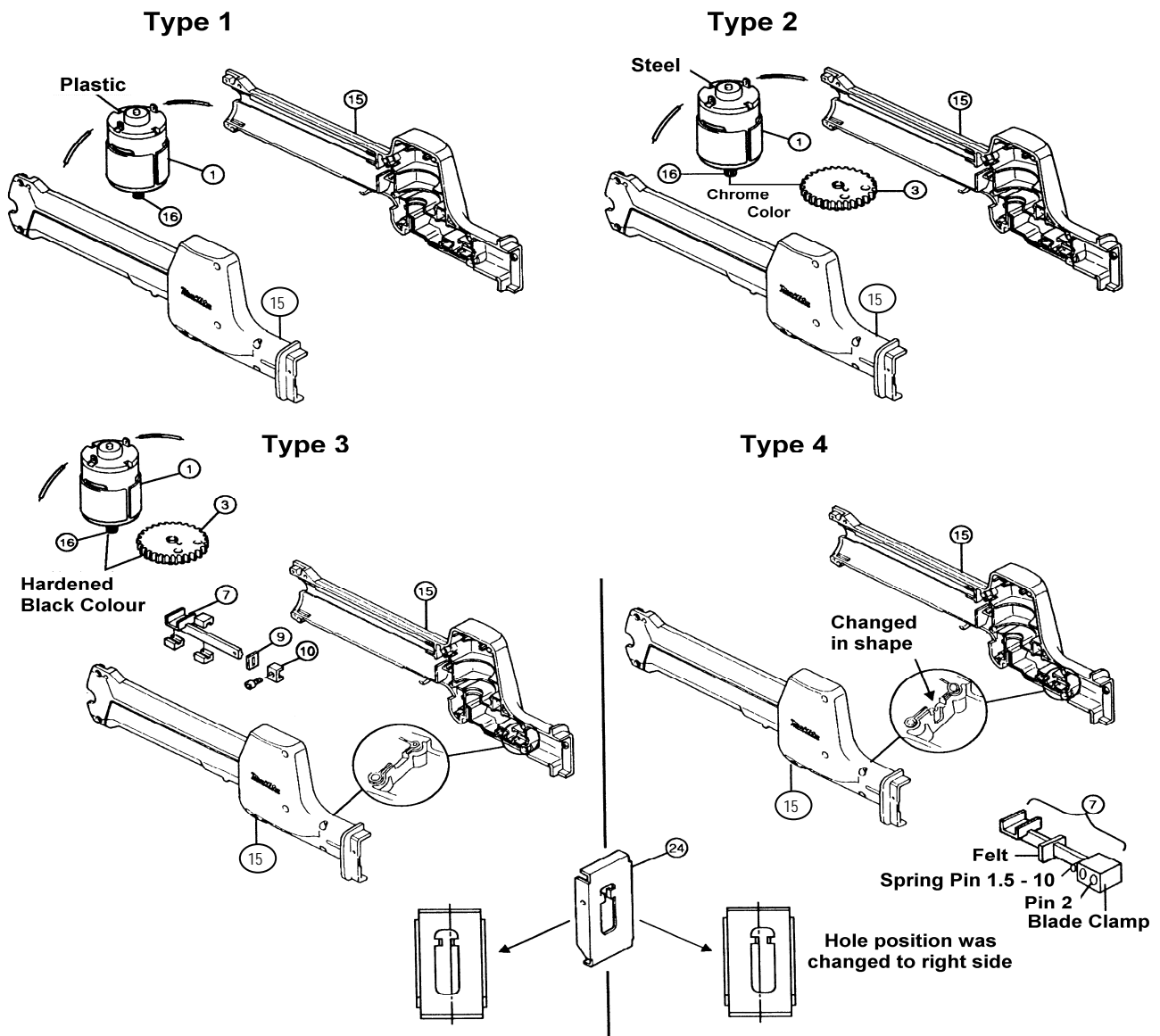

Service Notes

1. Type 2 Motor will fit into Type 1 Housing if the following parts are added.

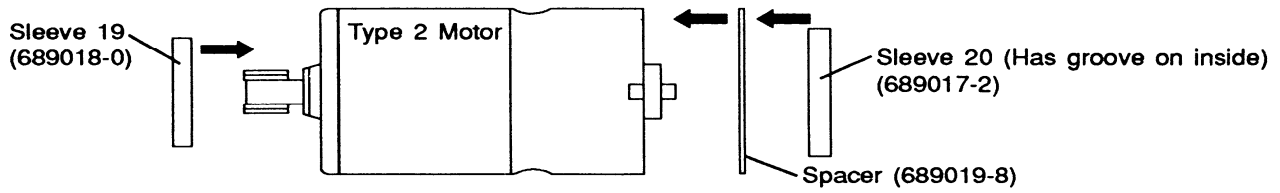

2. New method of installing Blades (For Type 4 Slider Com.)

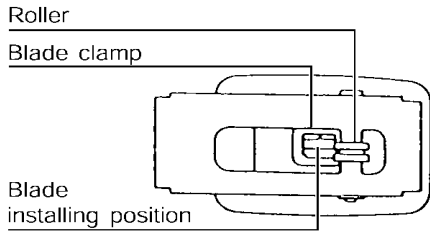

Loosen the blade securing bolt fully with the hex wrench. Keep the back edge of the blade fitting into the roller and insert the blade between the blade clamp and the slider as far as it will go. Make sure that you are inserting the blade into the proper position.

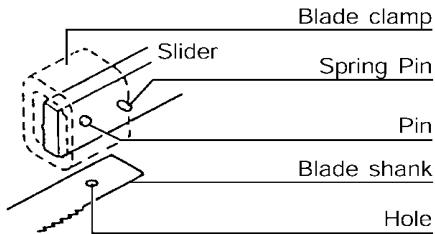

Fit the pin on the slider in the hole in the blade shank.
 Note:
 The hole in the blade shank will be aligned with the pin on the slider when the blade shank hits against the spring pin on the slider.

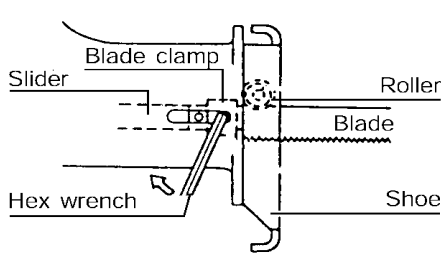

Tighten the bolt securely while making sure that the blade will not be extracted even though you try to pull it out.
CAUTION:
 If you tighten the bolt without the pin on the slider fitting properly in the hole in the blade shank, the pin or the blade shank will be damaged. This may cause the blade to be extracted unexpectedly during operation.